

SWING CHECK VALVES

CLASS
150 / 300 / 400



TECHNICAL DATA

MANUFACTURING STD.: BS 1868/API 6D
 TESTING & INSPECTION STD.: API 598/BS 5146
 FACE TO FACE: AS PER ANSI B 16.10
 END CONNECTIONS: FLANGED AS PER
 B 16.5 RF/BS 1560

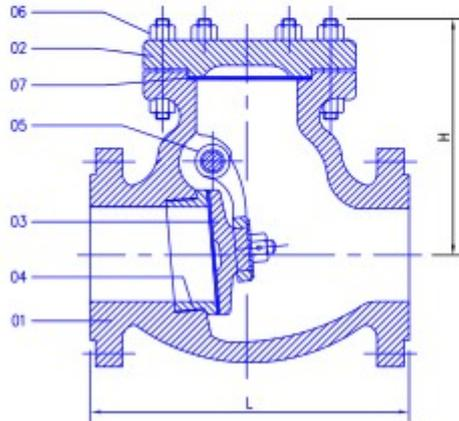

P. NO.	ITEM	QTY.	MATERIAL
01	BODY	1	ASTM A 216 Gr. WCB
			C.I. TO IS 210 Gr. FG 220
			ASTM A 351 Gr.CF8/CF8M/CN7M
02	COVER PLATE	1	ASTM A 216 Gr. WCB
			C.I. TO IS 210 Gr. FG 220
			ASTM A 351 Gr.CF8/CF8M/CN7M
03	DISC	1	C.S. WITH 13% Cr. FACING
			S.S.316/S.S.304
			TEFLON COATING OPTION
04	SEAT RING	1	C.S. WITH 13% Cr. FACING
			Integral Seat For Alloy Steel Valve
			AISI 304/AISI 316
05	DISC HINGE	1	ASTM A 216 Gr. WCB
			C.I. TO IS 210 Gr. FG 220
			ASTM A 351 Gr.CF8/CF8M/CN7M
06	STUD & NUT	Req.	ASTM A 193 Gr. B7
			ASTM A 194 Gr. 2H
07	COVER GASKET	1	SPIRAL WOUND SS 304 WITH CAF

NB		40	50	65	80	100	150	200	250	300	350	400	450	500	600
ASA - 150	L	165	203	216	241	292	355	495	622	698	787	914	914	940	965
	H	138	152	161	173	200	247	284	327	353	461	498	527	581	622
ASA - 300	L	241	267	292	317	356	445	533	622	711	812	838	914	990	1143
	H	159	176	187	194	257	284	331	368	400	511	552	581	616	664
ASA - 400	L	241	292	330	356	406	495	597	673	762	825	902	978	1054	1231
	H	175	190	200	205	229	306	358	400	415	541	581	608	654	692

HYDROSTATIC TEST PRESSURE		
CLASS	BODY	SEAT
150	425 PSIG	300 PSIG
300	1100 PSIG	750 PSIG
400	PSIG	PSIG

SERVICE RATING		
CLASS	PRESSURE	TEMP.
150	150 PSIG	500° F
300	300 PSIG	850° F
400	400 PSIG	850° F

ALL DIMENSION ARE IN MM

AVM Engineers

SWING CHECK VALVES

CLASS
600 / 900 / 1500 / 2500



TECHNICAL DATA

MANUFACTURING STD.: BS 1868/API 6D
 TESTING & INSPECTION STD.: API 598/BS 5146
 FACE TO FACE: AS PER ANSI B 16.10
 END CONNECTIONS: FLANGED AS PER
 B 16.5 RF/BS 1560

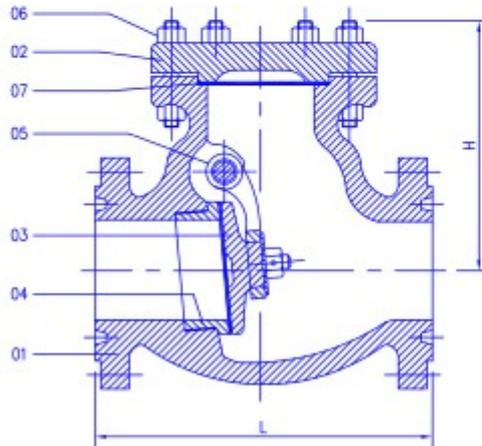

P. NO.	ITEM	QTY.	MATERIAL
01	BODY	1	ASTM A 216 Gr. WCB
			C.I. TO IS 210 Gr. FG 220
			ASTM A 351 Gr.CF8/CF8M/CN7M
02	COVER PLATE	1	ASTM A 216 Gr. WCB
			C.I. TO IS 210 Gr. FG 220
			ASTM A 351 Gr.CF8/CF8M/CN7M
03	DISC	1	C.S. WITH 13% Cr. FACING
			S.S.316/S.S.304
			TEFLON COATING OPTION
04	SEAT RING	1	C.S. WITH 13% Cr. FACING
			Integral Seat For Alloy Steel Valve
			AISI 304/AISI 316
05	DISC HINGE	1	ASTM A 216 Gr. WCB
			C.I. TO IS 210 Gr. FG 220
			ASTM A 351 Gr.CF8/CF8M/CN7M
06	STUD & NUT	Req.	ASTM A 193 Gr. B7
			ASTM A 194 Gr. 2H
07	COVER GASKET	1	SPIRAL WOUND SS 304 WITH CAF

NB		40	50	65	80	100	150	200	250	300	350	400	450	500	600
ASA - 600	L	241	292	330	356	432	558	660	787	838	889	990	1092	1193	1397
	H	175	190	200	205	229	311	375	378	435	565	592	642	694	735
ASA - 900	L	241	292	330	381	457	607	737	838	965	1029	1130	-	-	-
	H	175	190	200	259	281	359	419	451	489	628	663	-	-	-
ASA - 1500	L	304	368	419	470	546	705	832	991	1130	1257	-	-	-	-
	H	219	251	267	329	378	467	509	592	673	740	-	-	-	-
ASA - 2500	L	304	368	419	578	673	914	1022	-	-	-	-	-	-	-
	H	219	251	267	353	390	498	541	-	-	-	-	-	-	-

HYDROSTATIC TEST PRESSURE		
CLASS	BODY	SEAT
900	PSIG	PSIG
1500	PSIG	PSIG
2500	PSIG	PSIG

SERVICE RATING		
CLASS	PRESSURE	TEMP.
900	PSIG	* F
1500	PSIG	* F
2500	PSIG	* F

ALL DIMENSION ARE IN MM

AVM Engineers