



- Guaranteed dew point performance
- Design simplicity
- No refrigerants used
- Purge saving & Dew point dependent control system
- Compact digital CO & Dewpoint Monitor/Alarm
- Air quality mandated by NFPA 99
- Bacterial Penetration upto 0.0001%
- LED tower operation display indicating sequence of operation



Desiccant Compressed Air Dryer
**Medical Breathing
Air Dryers**

TBAS Medical Dryers

The TBAS medical dryers operate with the principle of Pressure Swing Adsorption, hence removing more moisture than refrigeration air dryers, and delivers moisture free dry air consistently irrespective of flow variation.

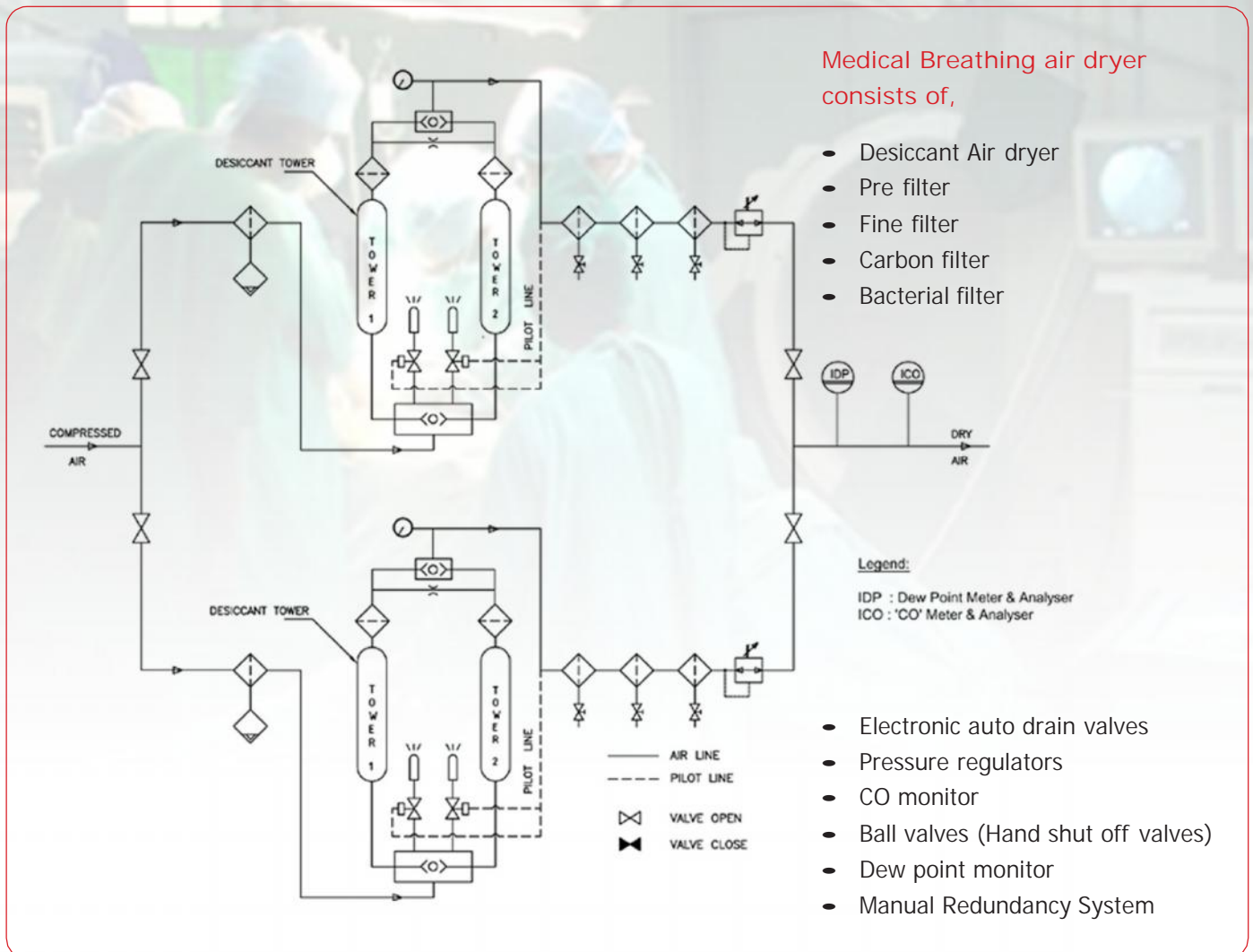

DESCRIPTION OF OPERATION

Drying cycle

The compressed wet air flows through the pre filter. The Liquid water particles get filtered by the filter. The filtered air flows in to the adsorber tower filled with desiccant where it loses all the moisture to the desiccant. Purified (Moisture and oil free) air further passing through the series filter to achieve the desired quality level as per Breathing Standard.

Regeneration Cycle

In order to remove the moisture during regeneration cycle. Small portion of dry air from the drying tower is passes over the desiccant through the regeneration orifice. This results in complete regeneration of desiccant and ready for the next cycle.

Item Code	Model TBAS *Simplex	L mm	B mm	H mm	Flow cfm	End Conn. BSP	Item Code	Model TBAS #Duplex	L mm	B mm	H mm
PM001	10S	625	540	1121	10	½"	PM009	10D	1150	800	1168
PM002	20S	625	540	1121	20	½"	PM010	20D	1150	800	1168
PM003	30S	625	540	1316	30	½"	PM011	30D	1150	800	1327
PM004	45S	663	648	1120	45	½"	PM012	45D	1150	800	1170
PM005	60S	808	740	1290	60	1"	PM013	60D	1150	838	1327
PM006	100S	823	740	1745	100	1"	PM014	100D	1343	800	1788
PM007	125S	823	740	2055	125	1"	PM015	125D	1343	805	2085
PM008	200S	865	795	1819	200	1½"	PM016	200D	1369	912	1819

Standard Features

* Single Medical breathing Air unit with CO and Dew Point Monitor (Simplex)

Dual Medical breathing Air unit with CO and Dew Point Monitor (Duplex) One Stand by unit with manual redundancy.

Operating Conditions

Voltage : 100 - 240 VAC, 50/60Hz, 1ph

Power Consumption : 40 Watt Max

Maximum working pressure : 16 bar (g)

Minimum working pressure : 4 bar (g)

Rated inlet Temperature : 38°C

Rated inlet pressure : 7 bar(g)

CO Level : 10 PPM (Alarm set point)
as per NFPA 99

Air Quality : 2°C PDP (Alarm set point)
as per NFPA 99
0.01 micron particle level.

Cycle Time : 4 min

Dewpoint dependent change over

The TBAS Series has robust valving and includes high quality coalescing pre-filter, a particulate fine-filter, a Activated carbon filter, and Bacterial filter mounted as a standard feature.

Coalescing - Pre Filter

The P-Grade (5 Micron) pre-filter element removes particulates, water aerosols, and oil mist content in the air.

Fine Filter

The X-Grade (1 Micron) Fine filter efficiently removes fine aerosols and desiccant powder particles from the adsorbent towers.

Activated Carbon Filter

This filter is used to remove oil and hydrocarbon vapor from the compressed air stream coming from the dryer. Odor and Taste free air at the outlet.

Bacterial Filter

Bacterial filters (0.01 Micron) provide effective protection against various types of particles including bacteria, viruses, and moisture droplets in the dry air out from the medical dryer.

These are help to protect the patient, and the breathing circuit, hospital pipe line from contamination, odor and taste free dry air at the outlet.

TBAS controller

TBAS medical breathing air dryer provides complete control of the system with LED indication/description of each step in the sequence of operation. A high quality Carbon Monoxide (CO) Monitor and Dew point monitor ensures the continuous monitoring of CO in PPM level and Water vapor concentrations in dewpoint deg °C in the Digital display to ensure the safety of all users.

TBAS Outstanding features and applications

Alarms

Compact digital carbon monoxide (CO) monitor, Dew point monitor. If the set value exceeds the standard value, it will give the alarm in the front panel.

Purge saving

Manual Purge economiser.

Dewpoint sensor for automatic purge control.

Construction

Corrosion free aluminium towers and blocks. All pipeline are in SS/Copper.

Display

LED indication for tower operation and sequence of operations.

Easy Integration

Easy installation and integration with existing equipment: All system tie-in points are on one side.

Safe

Heavy-duty adsorption vessels, designed and certified for an unlimited number of cyclic loads.

Customization

An extended list of options allow you to define your specific Trident Twin-Tower PSA breathing air dryer adjusted to your individual need.

The TBAS series breathing air dryer meets/exceeds the breathing air standards below.

<p>Breathing Air Quality :</p> <p>NFPA99</p> <p>OSHA : Grade D</p> <p>European Pharmacopoeia</p> <p>IS/ISO 7396</p>	<p>Statement of conformity for Dryer and Filter</p> <ul style="list-style-type: none"> • ISO 8573 Class - 2 : Outlet air quality • 97 / 23 / CE : Pressure Directive • 89 / 392 / CEE : Machinery Directive • 73 / 23 / CEE : Low Voltage • CRN
---	--

Sumved International

B-34, Punit Industrial Estate, Opposite Turbhe Railway Station, Next to BASF Company, Turbhe 400705 Mob : 91-9821449162, 9022666776

e-mail : info@sumvedinternational.com Website : www.sumvedinternational.com



Sales & Service

Dessicant Air
Dryer

TBAS Medical
Air Dryer

Nitrogen
Generator

Oxygen
Generator

Refrigerated Air Dryer

Air Filters