

4500 | INTUITIVE CASE CODING FOR UNMATCHED VALUE

Drop on Demand Valve Jet

Run it with the tip of your finger

Highly responsive color touch screen makes daily operations immediate and simple

Straightforward operation

Easy operation at your fingertips and in your local language thanks to its simple, intuitive, WYSIWYG 5.7 inch touch screen user interface.

More uptime in daily use

Clean plug and play consumable changeover in less than 30 seconds, with no daily maintenance required.

Extended connectivity for enhanced ease of use

Download or back up production data via USB stick. Avoid non-coded boxes with embedded conveyor stop output.

Simple installation & integration

Buy it, unwrap it and install it with ease even in the dustiest and most humid environments (IP54)

Fits on any line

Compactness and head positioning options make it ideal for hard to access production lines, variety of package sizes and environments.

Out of the box and directly on your line

No need for special training or plant air to install. Start printing 30 minutes after you open the box.

Smart consumable system. No set-up required.

Consumable management is automatic, clean and fully secure.

Ideal for seasonal use

Can be easily stored for weeks and restarted immediately (up to 3 months and without flushing).

Unmatched value

Identify your boxes with codes up to 56 mm high

Prevent product recalls and waste through consistent quality print

Latest printhead generation ensures text and logos are legible from a distance thus simplifying internal logistics.

Production uptime through its enhanced drop control system: More than 39,000 cartons* with one 1L ink bottle

Bottle can be replaced quickly for maximum uptime. 0,5L bottle also available.

Choice of colored inks

Choose between black or red for your porous packaging (cardboard, paper). Code will remain readable even in the toughest storage conditions.



Start printing 30 minutes after you open the box.
Step 1: Press ON, Step 2: Select job, Step 3: Press PRINT.



Multiple characters and logos in several languages.



39,000 coded cartons with just one 1L ink bottle.

*Based on a standard application of 16 characters, 7N-13mm dot size 3

4500 - Specifications

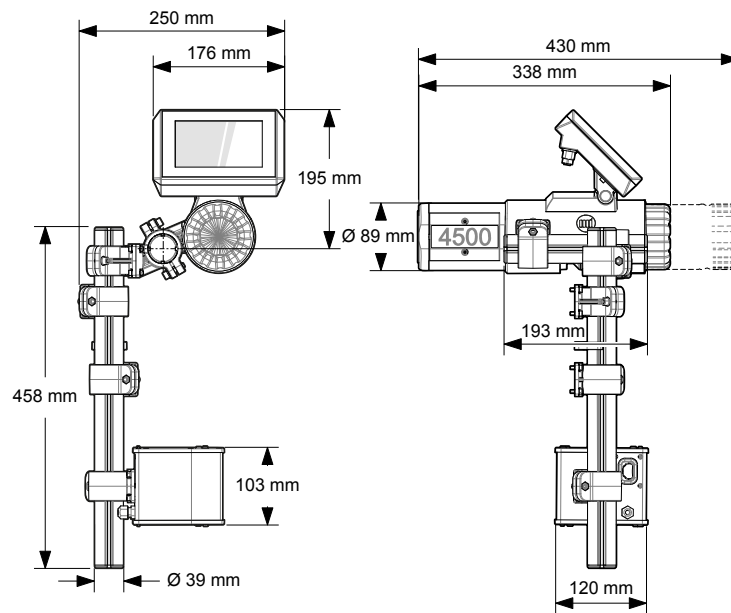

Print features

- 2 water based ink colors – black and red – for porous substrates
- 0.5 or 1L ink bottle, with ink level alarm. Indication of remaining ink on the screen
- 7 nozzle print heads to print 1 line of 13 mm or 24 mm
- 16 nozzle print heads to print 1 line of 29 or 56 mm or 2 lines of 13 or 24 mm each
- Prints text, time, date, expiration dates, shift code, counters, images (png or bmp)
- Calendar feature for custom date formats
- 200 messages minimum of 100 characters each
- Character width adjustment
- Print delay for message placement
- Top and side printing
- 2-20 mm print distance between the printhead and the object
- Print direction from right or left
- Print speed up to 60 m/min
- Ink circuit:
 - Internally regulated
 - No adjustments needed. No need of plant air
- Character sets: Unicode capability. Latin, Arabic, Cyrillic, Chinese (simplified), Chinese (traditional), Greek, Hebrew, Japanese, Thai, etc.
- Support for TrueType and BDF-font format
- Font matrix:
 - 7N: 5x5, 7x5
 - 16N: 5x5, 5x7, 12x7, 16x10

Operations

- One button only, to activate/deactivate print
- Operator interface: intuitive icon-based WYSIWYG 5.7" (144.8 mm) touch screen
- Interface available in 32 languages: Arabic, Brazilian, Bulgarian, Chinese (simplified), Croatian, Czech, Danish, Dutch, English, Finnish, Greek, Hebrew, Hungarian, Indonesian, Italian, Japanese, Korean, Norwegian, Farsi, French, German, Polish, Portuguese, Romanian, Russian, Slovenian, Spanish, Swedish, Taiwanese, Thai, Turkish, Vietnamese
- 3 user levels (Operator, Advanced Operator and Administrator)
- Full message editor included
- Instructions can be given in one language while messages can be printed in another language and/or character set
- Import/export jobs and printer settings through USB
- Direct purge button function on controller for convenient cleaning
- Supplied as complete functional system 'out-of-the-box'

Other characteristics

- Manual set or built-in print speed detection
- Object detection by integrated photocells
- Conveyor stoppage output on printer error
- Optional external signal beacon
- Gregorian, Julian and Hijri calendars
- Operating temperature: 5° to 45° C (41° to 113° F)
- Weight: approx. 4.5 kg (9,92 lbs) without ink bottle
- Humidity: from 10 to 90% without condensation
- Protection class: IP54
- Power supply: 100/240 V AC, 50/60 Hz. External AC/DC power pack. 24 V (DC): 1.5 A
- Included: printer, brackets, power supply, cable, DVD-Rom with instruction and user manuals

We reserve the right to amend the design and/or specifications of our products without notice.

Markem-Imaje
Global Sales & Marketing Division
9, rue Gaspard Monge
B.P. 110
26501 Bourg-lès-Valence Cedex France
Tél. : +33 (0) 4 75 75 55 00
Fax : +33 (0) 4 75 82 98 10



To learn more, visit www.markem-imaje.com