

Technical Data SF Series

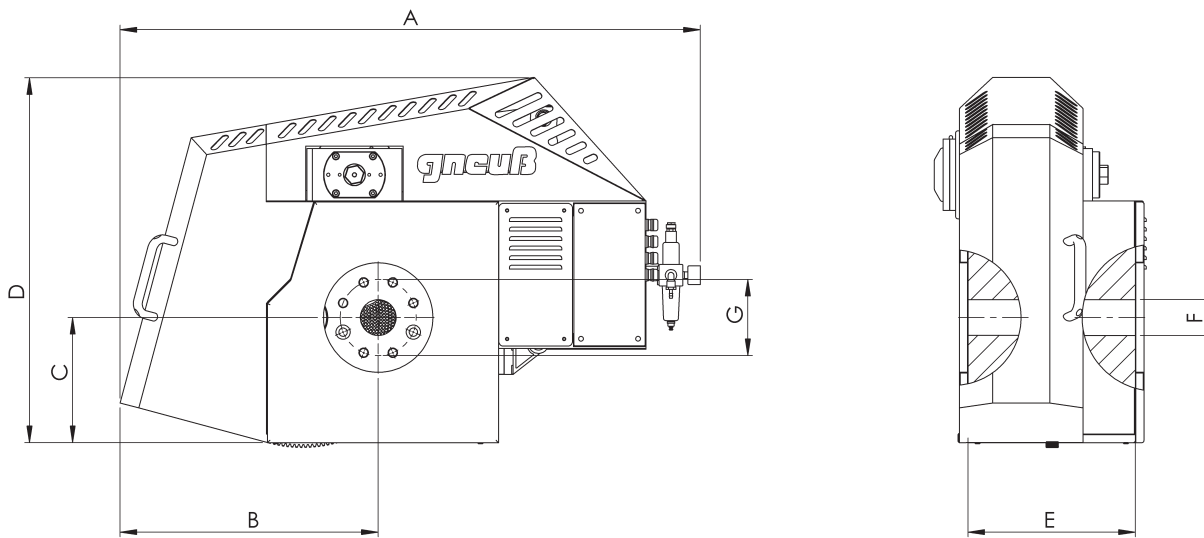

filter type	screen area	heating capacity in watt		heater zones (1)	pressure in bar max. (2)	temp. in °C max. (3)	Q in kg/h (4)	dimensions in mm							weight in kg
		electric	oil/vapor					A	B	C	D	E	F	G	
SF 30	8	1200	6000	2	350	320	40	460	154	250	90	95	15	90	30
SF 45	19	1900	6000	2	350	320	120	560	210	335	130	138	20	120	75
SF 60	35	3090	6000	2	350	320	220	670	270	420	150	172	20	240	115
SF 75	45	5860	9000	2	300	320	310	720	290	440	170	225	25	175	220
SF 90	70	7300	12000	2	300	320	550	900	395	580	220	319	30	220	460
SF 130	135	8000	12000	2	300	320	910	950	432	630	245	352	30	220	530
SF 150	180	8000	12000	2	300	320	1430	950	432	630	245	352	35	220	550
SF 175	250	12000	18000	3	300	320	2080	1100	550	940	305	400	40	310	1200
SF 200	320	-	36000	-	250	320	2850	1200	635	1150	360	445	45	320	1680
SF 250	500	-	36000	-	250	320	4070	1300	690	1170	400	545	50	370	2300

(1) = 1 heater zone for liquid heating.

(2) = High pressure versions available as an option.

(3) = Up to 350 °C possible as an option.

(4) = Based on: MFI 2-5, filtration fineness 200 µm and differential pressure 50 bar.