



Bringing Excellence of Engineering to
Wood Industries



POST FORMING

NR - 149



Technical Specification

Description	Unit	NR - 149
Max Job Length	mm	2440
Min. Job Length	mm	300
Job Thickness Range	mm	16-125
Min. Job Width	mm	150
Max Heating Temp	c	200
Compressed Air Requirement	Kg-cm2	7
Heating Element	KW	3
Electric Motor - 3Phase	HP	0.5

*Specifications are subjected to change without notice.

Salient Features

- Automatic Post forming cycle.
- Pneumatic cylinders to apply uniform pressure on job for effective bonding of Laminates.
- Facility for manual and Automatic
- Hard chrome plated heater bar for smooth operation and long life.
- Mechanical drive control.
- Drive motor with brake is provided to avoid slippage of rotary part.

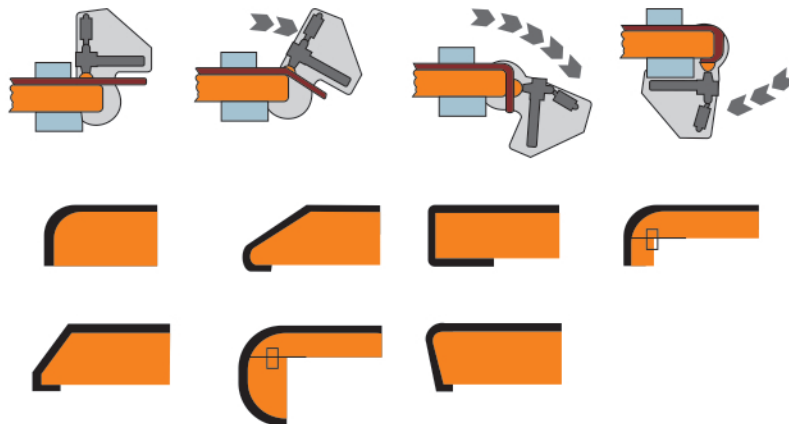

Nihar Industries

Manufacturer & Exporter of Wood Working Machineries & Spares

An ISO 9001 : 2015 Certified Company

Plot No. 85/3, Phase-I, G.I.D.C., Vatva, Ahmedabad-382 445. (Gujarat) INDIA.

Land Line : +91-79 29703831, Mobile : +91 98252 13831, +91 93770 54746, +91 93771 54750

E-mail : info@niharindustries.com, Website : www.niharindustries.com