

**HEAVY DUTY
WELDABLE
TOGGLE CLAMP-
MODULAR DESIGN**

These are modular weldable clamps which allow the designer complete flexibility to position the base, clamp arm and handle and weld them in any desired position to suit the application. The base, arm and the pipe handle are supplied alongwith the clamp separately, to be welded by the user before use. The main body is made of accurately machined components having hardened and ground pivots pins and bushes.

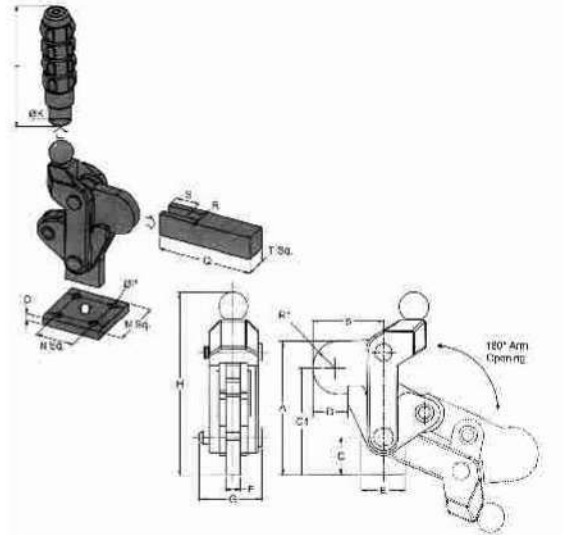
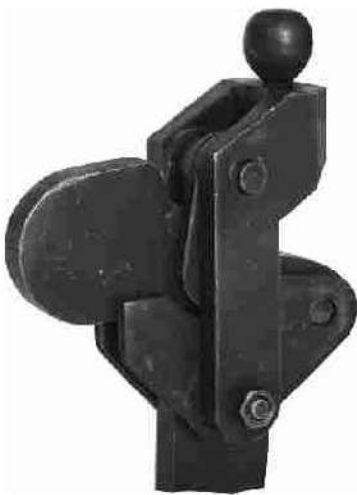

ITEM CODE	MODELS	A	B	C	CI	D	E	F	G	H	K	L	M Sq.	N Sq.	O	P	Q	R	S	T Sq.	RI	HOLDING CAPACITY	WEIGHT in kgs.
I3601	PWTC-200	75	40	22	37	17	24	8	41	106	16	75	8	45	6	7	75	8	15	20	16	200 kgs	0.726
I3602	PWTC-300	90	53	26	47.5	26	30	10	44	127	22	90	10	30	8	6.5	90	10	21	22	17.5	300 kgs	0.860
I3603	PWTC-500	100	60	31	51.5	30	37	12	58	151	22	100	12	40	9	9	100	12	25	25	22	750 kgs	2.000