

FULL GEAR HALF RIGID COUPLINGS

MINIMUM CLEARANCE REQUIRED FOR ALIGNING

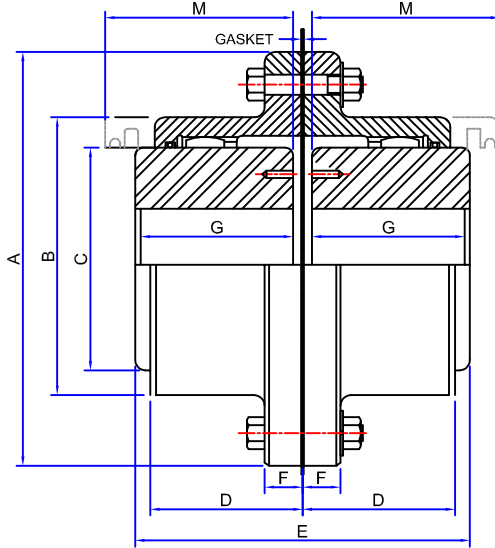

RATINGS AND DIMENSIONS. SIZE 100 TO 110

SIZE	MAX BORE MM.	PILOT BORE MM.	Lode Capacity		MAX RPM	Wt. With Solid hubs Kg.	Gd <sup>2</sup> Kg.M.	DIMENSION IN MM.								
			Torque Kg. M.	H.P. Per 100RPM				A	B	C	D	E	F	G	H	M
100	30	10	50	7	8000	4.2	.03	120	75	50	39.5	93	15	45	1.5	45
101	44	20	100	14	6300	10	.14	170	100	65	49	115	17	55	2.5	65
102	52	30	250	35	5000	15	.20	185	125	85	62	145	17	70	2.5	80
103	65	40	450	63	4000	26	.48	220	150	105	78	175	20	85	2.5	105
104	80	50	850	119	3350	40	.95	250	175	130	96	250	20	105	2.5	125
105	100	75	1300	182	2800	62	1.90	290	200	155	106	230	25	110	5.0	140

**Suni® Cranes Controls**

AN ISO 9001:2015 CERTIFIED COMPANY



**सनी क्रेन्स कन्ट्रोलस**

एन आय.एस.ओ. १००१:२०१५ सर्टीफाईड कम्पनी

**Shubh Indl. Estate Vasai(E) PALGHAR-401208**

ALL DIMENSIONS ARE IN MM.

TOL — OVERALL DIM ±5MM.  
BOLTING CENTER ±3MM.

TITLE.

**FULL GEAR HALF RIGID COUPLINGS**

DRN.

PRAKASH

29/03/16

SCALE

N.T.S.

CHD.

MATL.

AS ABOVE

APPD.

TYPE NO.

DRG. NO.

REV -0