

Essential

Stairlift





INSTALLATION GUIDE

Part No. 001021
16-m07-2015

Standard notations

The following notations may be used throughout this guide to emphasize important safety information, mechanical concerns, and other important information. Lehner Lifttechnik recommends that you review and follow all of these messages.

 DANGER	Danger messages indicate an imminently hazardous situation, which, if not avoided, results in death or serious injury. All danger messages feature a standard ISO safety alert symbol followed by the signal word DANGER in capitalized black lettering on a red background.
 WARNING	Warning messages indicate a potentially hazardous situation, which, if not avoided, could result in death or serious injury. All warning messages feature a standard ISO safety alert symbol followed by the signal word WARNING in capitalized black lettering on a dark yellow background.
 CAUTION	Caution messages indicate a potentially hazardous situation, which, if not avoided, could result in death or serious injury. All caution messages feature a standard ISO safety alert symbol followed by the signal word CAUTION in capitalized black lettering on a yellow background.
CAUTION	Caution messages that do not include the ISO safety alert symbol indicate a potentially hazardous situation for the machine only, which, if not avoided, could result in damage to the machine. All caution messages include the signal word CAUTION in capitalized black lettering on a yellow background.
NOTE	Note messages provide information, such as reminders, general information about a previous statement, or additional guidelines that do not fit into the flow of the preceding text. All note messages include the signal word NOTE in capitalized white lettering on a blue background.

Hazards and warnings

 ELECTRICAL SHOCK HAZARD
Do not connect/disconnect wiring while the power is on. Before servicing, disconnect all power to the equipment.

 WARNING
SUDDEN MOVEMENT HAZARD System may start unexpectedly upon application of power. Stay clear of moving parts to avoid injury.

 ELECTRICAL SHOCK HAZARD
Savaria Corporation is not responsible for any modifications of the product made by the user. Do not allow unqualified personnel to use the equipment. Failure to comply could result in death or serious injury. Maintenance, inspection, and replacement of parts must be performed only by authorized personnel familiar with installation, adjustment, and maintenance. Do not remove covers or touch circuit boards while power is on.

 WARNING
FIRE HAZARD Do not use an improper voltage source. Before applying power, verify that the rated voltage matches the voltage of the incoming power supply.

Job site tools

- Saw to cut the rail (recommended blade for a 12" mitre saw is an aluminum or non-ferrous metal reverse-rake blade)
- Allen keys (Metric)
- Screwdrivers (slotted, Phillips, Robertson)
- Socket and wrench set
- Needle-nose pliers
- Rubber mallet
- Hammer
- Box cutter/knife
- Scissors
- Tape measure
- Carpenter's level and square
- Reversible hand drill
- Concrete drill bits 1/4", 3/8", 1/2" (if applicable)
- Hammer drill for concrete fasteners (if applicable)
- Flashlight
- Wire crimper
- Wire strippers
- Tie-wraps
- Volt-ohm (multi) meter
- Safety items as required: safety glasses, safety shoes
- Hand dolly
- Shop vac
- Rags and cleaning solvent
- Tube of grease (included in chair box)

Disclaimer

Lehner Lifttechnik GmbH disclaims liability for any personal injury or property damage resulting from the operation of a product that has been modified from the original Savaria design. No person or company is authorized to change the design of this product without written authorization by Lehner.

List of installation steps



WARNING

Follow the steps provided to ensure your safety during installation. Failure to follow instructions renders the Limited Warranty null and void. In addition, any party installing the product who deviates from the installation instructions agrees to indemnify, save, and hold harmless the manufacturer from any and all loss, liability, or damage that may occur as a result of the deviation.

The following table lists the installation steps.

Step	Page
Double-check site specifics	4
Unpack and check shipment	4
Determine handing	5
Cut rail to length	6
Connect rail sections together (if required)	8
Install bottom charging strips	9
Position rail assembly on stairs	10
Install carriage on rail	11
Install top charging strips and charger	13
Level seat post (if required)	13
Install seat assembly	14
Anchor rail assembly in place	14
Adjust arms (if required)	15
Adjust footrest (if required)	15
Install limit switch cams	16
Install mechanical stops	16
Mount charger	17
Check installation, lubricate and clean	17
Test operation	18
Manual emergency operation	18
Before leaving job site	19
Appendix A Reference Information	20
Appendix B Maintenance	23

Step 1 Double-check site specifics

Double-check all site specifics and preparatory work by others prior to installation.

Procedure

- 1 Prior to delivery, ensure that you have clear access to the installation site.
- 2 For job site verification, use the following information sources:
 - Written and verbal direction from the customer and any contractors involved in the installation.
- 3 Ensure that the width of the stairway will accommodate the stairlift in the unfolded position.
- 4 Ensure that the stair steps will support the maximum load of the stairlift (300 lb/136 g).
- 5 Ensure that there is a standard household 110 V AC power outlet located at the top or bottom of the stairs to plug in the charger.
- 6 Ensure that all electrical equipment and wiring comply with the applicable codes.
- 7 Ensure that there are no fire and safety issues. Contact Savaria's *Technical Support* at 1 (800) 791-7999 if necessary.
- 8 Ensure that there is adequate lighting along the stairway and at the landings.

Step 2 Unpack and check shipment

Unpack and check the contents of the shipment.

Procedure

- 1 Prior to installation, unpack the shipment and check the contents.
 - The shipment comes in three boxes. The carriage assembled with footrest and seat post are in one box, the seat and fitting kits are in the second box, and the lower and upper rail assemblies are in the third box.
 - Note that all hardware and miscellaneous parts are on cardboard and shrinkwrapped in place.
- 2 Check the condition of the shipment for any damage; installing damaged parts can lead to safety violations and void the limited warranty. Contact Savaria's *Technical Support* if any parts are damaged.

NOTE

If possible, take a photograph of any damaged part(s).

Step 3 Determine handing

Determine whether you will be installing a left-hand or right-hand unit.

Procedure

A right-hand unit will be installed on the right side of the stairs (shown below), and a left-hand unit will be installed on the left side of the stairs.

Figure 1



Right-hand unit installed on right side as viewed from bottom of stairway

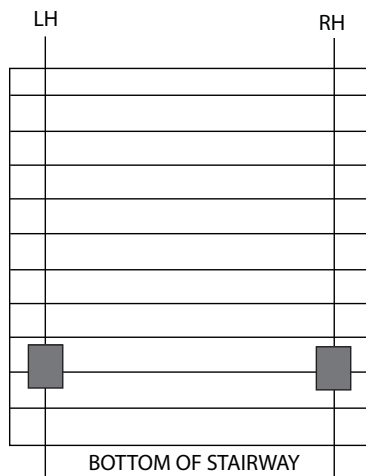

NOTE

When you are at the bottom landing looking up the stairway, the steel gear rack will always be on the LEFT side of the aluminum rail regardless of the handing of the unit.

Step 4 Cut rail to length

Cut the rail to length as required.

Procedure

- 1 Measure the travel of the stairs from the nose at the top landing to the floor at the bottom landing (**nose to floor** in Figure 2 below).

Figure 2

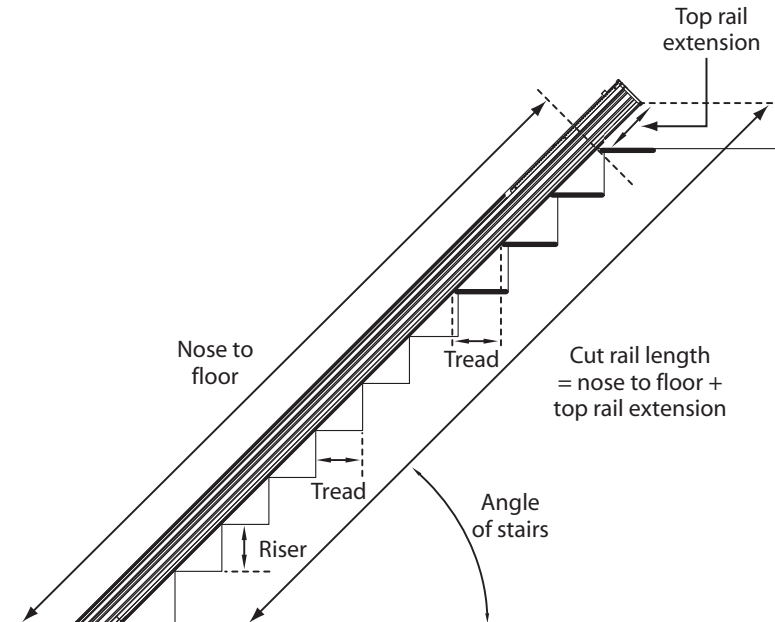

- 2 Use the chart below to determine the **angle** of the stairs from the riser and tread measurements. For example, with a riser of 8.5" and a tread of 10", the angle of the stairs is 40°.

Chart to determine angle of stairs (degrees)

		Tread												
		12	11.5	11	10.5	10	9.5	9	8.5	8	7.5	7	6.5	6
Riser	6	27	28	29	30	31	32	34	35	37	39	41	43	45
	6.5	28	29	31	32	33	34	36	37	39	41	43	45	47
	7	30	31	32	34	35	36	38	39	41	43	45	47	49
	7.5	32	33	34	36	37	38	40	41	43	45	47	49	51
	8	34	35	36	37	39	40	42	43	45	47	49	51	53
	8.5	35	36	37	38	40	42	43	45	47	49	51	53	55
	9	37	38	39	41	42	43	45	47	48	50	52	54	56
	9.5	38	40	41	42	44	45	47	48	50	52	54	56	58
	10	40	41	42	44	45	46	48	50	51	53	55	57	59
	10.5	41	42	44	45	46	48	49	51	53	54	56	58	60
	11	43	44	45	46	48	49	51	52	54	56	58	59	61
	11.5	44	45	46	48	49	50	52	54	55	57	59	61	62
12	45	46	47	49	50	52	53	55	56	58	60	62	63	

- 3 Use the table below to find the **top rail extension length (E)** based on the rail angle (A) and the seat height (H). For example, with a rail angle of 40° and a seat height of 18", the rail extension length required is 7-3/4".

Figure 3

Rail Extension Length (E)					
H A	18"	19"	20"	21"	22"
25 deg	5 3/4" (146 mm)	8 1/8" (206 mm)	10 1/2" (266 mm)	12 7/8" (326 mm)	15 1/4" (387 mm)
30 deg	6 1/2" (164 mm)	8 1/2" (216 mm)	10 1/2" (266 mm)	12 1/2" (316 mm)	14 1/2" (367 mm)
35 deg	7" (180 mm)	8 7/8" (225 mm)	10 1/2" (269 mm)	12 3/8" (313 mm)	14" (355 mm)
40 deg	7 3/4" (196 mm)	9 1/4" (235 mm)	10 1/2" (275 mm)	12 3/8" (314 mm)	14" (355 mm)
45 deg	8 1/4" (210 mm)	9 3/4" (246 mm)	11 1/8" (282 mm)	12 1/2" (318 mm)	14" (355 mm)

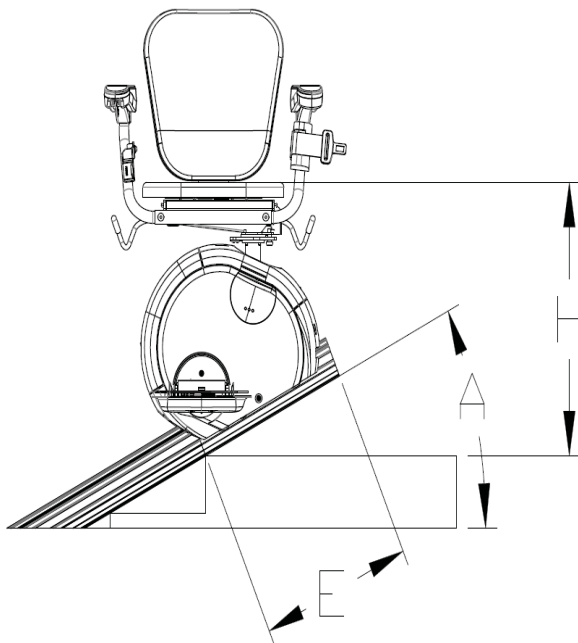

- 4 Add the nose to floor measurement (see Figure 2) to the top rail extension length (from Figure 3 above) to get the **total cut rail length**.

NOTE

- The top and bottom rail assemblies are the same.
- Always cut the rail from the top of the track.
- Always cut the aluminum separate from the steel rack.
- If you need a lower seat height at the bottom landing, you can cut the rail on a 45° angle and order a 45° end cap.

- 5 **IMPORTANT:** Before cutting the rail, make sure you remove any items that are shipped inside the rail cavity.
- 6 Follow either step 7 or 8 to cut the rail.

NOTE

The recommended blade (for a 12" mitre saw) is an aluminum or non-ferrous metal blade with a reverse rake on the teeth.

- 7 If using only one rail assembly only:
- Mark the aluminum rail at the cut length determined by the nose to floor plus top rail extension, measured from the heel at the bottom of the rail (the shorter side of the rail).
 - Remove the steel rack from the section of aluminum rail to be cut.
 - Cut the aluminum rail to length.
 - Insert the steel rack back into the rail. Insert the extra piece of steel rack, if required. Ensure the rack sections are pushed tightly together and mark the steel rack 3/4" from the top of the cut rail (to allow for installation of the top rail end cap).
 - Remove the steel rack section and cut it as marked.
 - Set this piece of steel rack aside to be installed **after** the carriage is installed on the rail.

NOTE

If you are joining two rail sections together (as described below) and the second rail section is too short to accommodate two legs, you need to cut the bottom rail section as well.

- 8 If the total travel is such that you need to join two or more rail sections together:
- Place the rail sections on the floor end to end.
 - Mark the aluminum rail at the cut length determined by the nose to floor plus top rail extension, measured from the heel at the bottom of the rail (the shorter side of the rail).
 - With the rail sections still end to end, slide the steel rack from the upper rail down to fill in the space in the lower rail. There should be a 1 meter rack length with the center point at the joint in the aluminum rail.
 - Remove the steel rack from the section of aluminum rail to be cut.
 - Cut the aluminum rail to length.
 - Insert the steel rack back into the rail. Insert the extra piece of steel rack, if required. Ensure both the rail and rack sections are pushed tightly together (so the rack fills up the entire length of rail) and mark the steel rack 3/4" from the top of the cut rail (to allow for installation of the top rail end cap).
 - Remove the top steel rack section and cut it as marked.

- h. Set this piece of steel rack aside to be installed **after** the carriage is installed on the rail.

NOTE

Do not remove any of the rack screws once the rack is completely installed. If you do, you will have to remove the complete rack in order to reinstall the rack screws.

Step 5 Connect rail sections together (if required)

Connect the rail sections together (if required) using the splice bars provided.

Procedure

Depending on the total travel of the unit, you may have to connect additional rail sections to the initial rail section.

Connect the rail sections together using the rail splice bars (one at the front and one at the back of the rail).

- 1 Place the rail sections on the floor end to end.
- 2 Insert the splice bar into the lower T-slot on the front of one rail section. Tighten the two screws to secure it in place. See Figure 3 below.
- 3 Insert the splice bar into the lower T-slot on the back of the same rail section. Tighten the two screws to secure it in place. See Figure 3 below.
- 4 Slide the second rail section into place over the splice bars.
- 5 Push the two sections firmly together ensuring there are no gaps in the rail. See Figure 4 below.
- 6 Tighten the two screws per splice bar to secure the two sections together.
- 7 Repeat steps 2 to 6 above for additional rail sections.
- 8 When the rail is assembled, slide all rack sections into place keeping the 800 mm long (or cut length) rack as the top section.

Figure 4

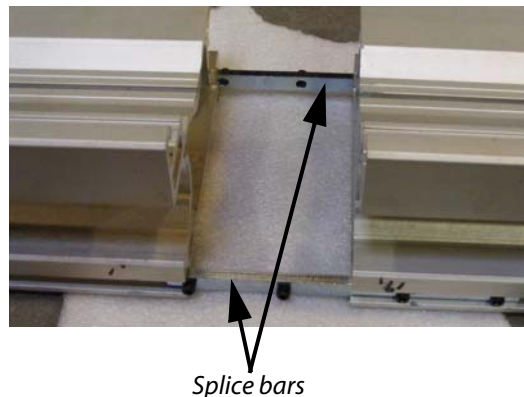

Step 6 Install bottom charging strips

Install the bottom charging strips in the rail.

Procedure

- 1 There are four charging strips - two at the top of the rail and two at the bottom of the rail. All positive connectors are RED; all negative connectors are BLUE.

Figure 5



- 2 At the bottom end of the rail, insert the charging strips into the slots on both sides of the rail. Push the charging strips down so they are **2" from the bottom of the rail**.
- 3 Secure each strip in place by tightening the screw.

Figure 6

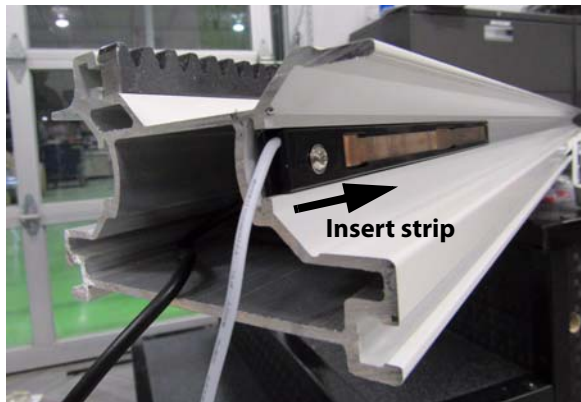

Strip
installed
2" from
bottom

- 4 Measure the amount of charging cable required to run the length of the rail to attach to the charging strips at both ends. Cut the cable to length if desired, or you can leave it inside the rail.
- 5 Feed the charging cable through the rail so it comes out both the top and bottom of the rail.
- 6 The charger can be installed at the top or bottom of the rail as required, depending on where your wall outlet is located. This procedure assumes you will be installing the charger at the top of the stairs.

NOTE

Connect the **positive** charging strip on the **rack side**. **Red (positive)** goes under the **rack**, always.

- 7 At the bottom of the rail, plug the red-ended wire from the POSITIVE charging strip into the red spade connector on the charging cable. Plug the blue-ended wire from the NEGATIVE charging strip into the blue spade connector on the charging cable.

Figure 7

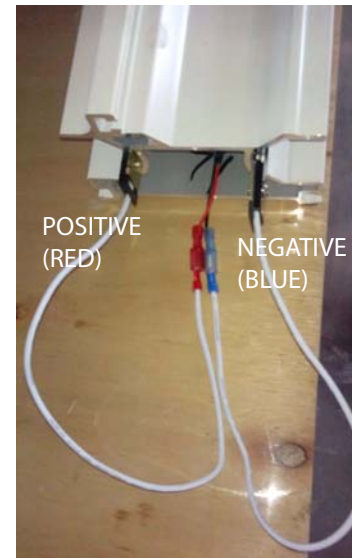

- 8 **IMPORTANT:** Before you install the bottom rail cap, be sure to insert the T-bolts into the lower slots of the rail (front and back) for the lower rail mounting brackets. You will not be able to insert them once the cap is on and the rail is on the stairs.
- 9 Install the bottom plastic rail cap.

Figure 8



- 10 You will install the top charging stations and connect the charger after installing the carriage onto the rail.

Step 7 Position rail assembly on stairs

Position the rail assembly on the stairs and attach the rail mounting brackets.

Procedure

- 1 When installing the rail assembly and mounting brackets, observe the following:
 - a. Ensure that there are six sets of rail mounting brackets for every 16 ft (4.9 m) of rail.
 - b. Never install the rail mounting bracket sets more than 40" (1016 mm) apart.
 - c. Always install rail mounting brackets on both sides of a splice (on the step above and below the splice).
- 2 To prepare for installation of the rail mounting brackets (both sides of the rail), slide the required number of T-bolts into the lower slots at the front and back of the rail.

Figure 9

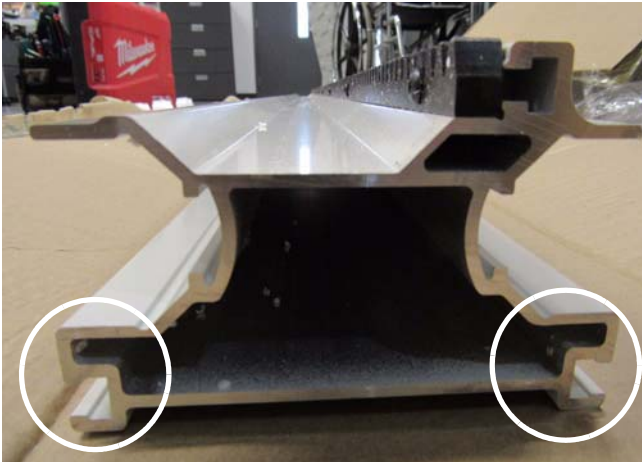

- 3 Carefully position the rail assembly on the nose of the steps with the bottom of the rail assembly touching the floor, or slightly off the floor. Ensure the gear rack is on the LEFT side of the rail.
- 4 Attach the rail mounting brackets to the rail using the T-bolts in the slots and the acorn nuts.

Figure 10



- 5 Make sure there is a mounting bracket at the bottom step and the top step, and then brackets in between no more than 40" apart.
If you have an uneven area with no clearance for the rail using standard mounting brackets, you can use the mounting extension brackets (310294 and 310295) from the extension kit 310293 instead.
- 6 Do not anchor the rail brackets to the steps until after the carriage is installed on the rail and the rail is in its final position.

Step 8 Install carriage on rail

Install the carriage on the rail.

Procedure

NOTE

IMPORTANT

Prior to installing the carriage on the rail, make sure the overspeed 'brake dog' is reset in case it was tripped during transport and handling.

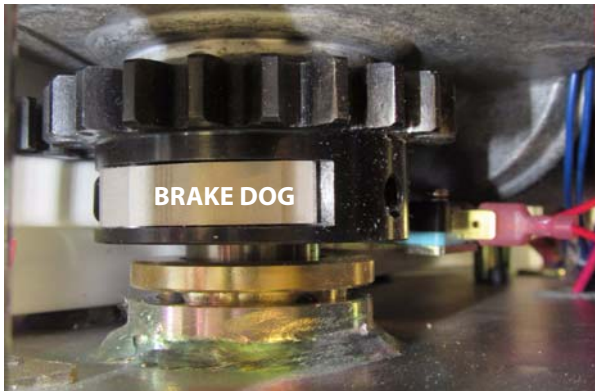

- 1 Before installing the carriage on the rail, make sure the rail sections are spliced together properly (if applicable) and the gear rack is tightened down in all sections of the rail.
- 2 Leave the top section of rack out of the rail until the carriage has been run towards the bottom.
- 3 Bring the carriage to the top of the stairway. **BE CAREFUL – THE CARRIAGE IS HEAVY.**
- 4 Lift the carriage up to the end of the rail, oriented with the footrest facing in toward the stairway.
- 5 Make sure the rollers line up with the rail and then carefully slide the carriage onto the rail.

Figure 11

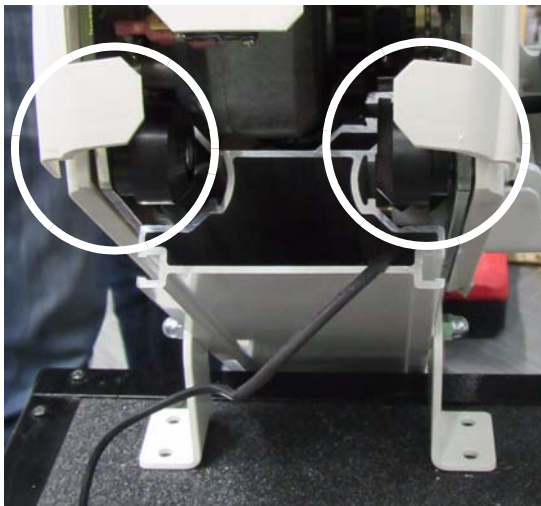

- 6 Make sure the seat jumper is plugged in (circled in the photo below).

Figure 12



- 7 To install the top section of steel rack, you need to move the carriage down the rail.
 - a. Flip the main power ON/OFF switch on the carriage to ON.

NOTE

If the main power ON/OFF switch is turned OFF, the stairlift batteries will not charge.

- b. Make sure the three LEDs on the front of the carriage come on.

Figure 13



- c. Install batteries in the remote control CALL/SEND units (shown below).

Figure 14



- d. Use the remote to move the carriage down the rail far enough to install the top section of steel rack.
- e. If the remote does not work, you may need to program it as described below; otherwise, go to the next step.
 - If you need to program the remotes, you have to remove the carriage cover to access the PCB. Place a flat blade screwdriver carefully under a corner of the cover and gently pry out to pop the cover off.

Figure 15



- Install and tighten the hardware to secure the top rack sections in place.

Figure 16

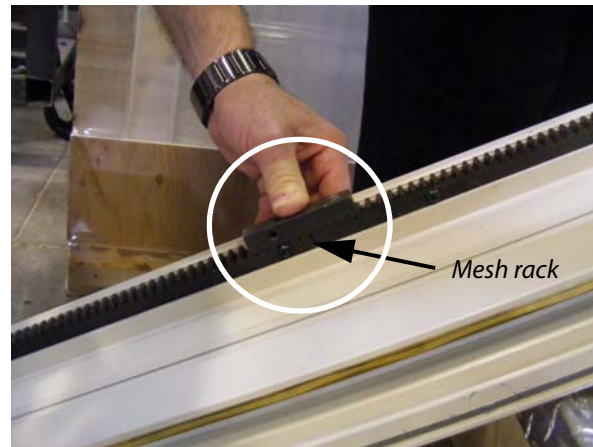

- Turn on power to the carriage.
 - Push and hold the remote program button on the board in the carriage and the amber LED will come on (see PCB layout in Appendix A).
 - Push any button on the remote and the amber LED will go off. Release the program button on the board. The remote is now programmed.
 - Repeat the above procedure for the second remote.
 - **Note:** If there are two units in the same area, remove the back cover of the remotes and change the DIP switch settings to a different combination and reprogram.
- 8 Insert the previously cut top section of steel rack into the rail as follows:
 - a. First, check this piece of rack for fastener holes. You need at least two fasteners to secure this short section to the top of the rail.
 - b. If the piece of rack can be secured with two fasteners, follow the steps below:
 - Mesh the top rack section with the existing rack section using an inverted piece of rack as shown at the right.
 - Position the inverted piece of rack over the rack joint and then tap down on the inverted piece to pull the sections of rack together.
 - Install and tighten the hardware to secure the rack section in place.
 - c. If the piece of rack cannot be secured with two fasteners, a long section of rack will need to be cut:
 - Mesh the rack sections tightly together using an inverted piece of rack as shown below.
 - Position the inverted piece of rack over the rack joint and then tap down on the inverted piece to pull the sections of rack together.

Step 9 Install top charging strips and charger

Install the top charging strips and the charger.

Procedure

- 1 **IMPORTANT:** Turn OFF the key switch and make sure the charger is NOT plugged in.
- 2 At the top end of the rail, insert the charging strips into the slots on both sides of the rail (in the same manner as for the bottom ones). Push the strips down so they are **1" from the top of the rail**.
- 3 Secure each strip in place by tightening the screw.
- 4 All the BLUE-ended wires plug into one 3-way spade connector and all the RED-ended wires plug into the other 3-way spade connector.
- 5 Connect the blue-ended wire from the NEGATIVE charging strip and the blue-ended wire from the charging cable into the double end of the 3-way spade connector. Connect the blue-ended wire from the charger into the single end of this 3-way spade connector.
- 6 Connect the red-ended wire from the POSITIVE charging strip and the red-ended wire from the charging cable into the double end of the 3-way spade connector. Connect the red-ended wire from the charger into the single end of this 3-way spade connector. **NOTE** that RED (positive) goes under the rack, always.
- 7 Carefully tuck all wires inside the end of the rail.

Figure 17

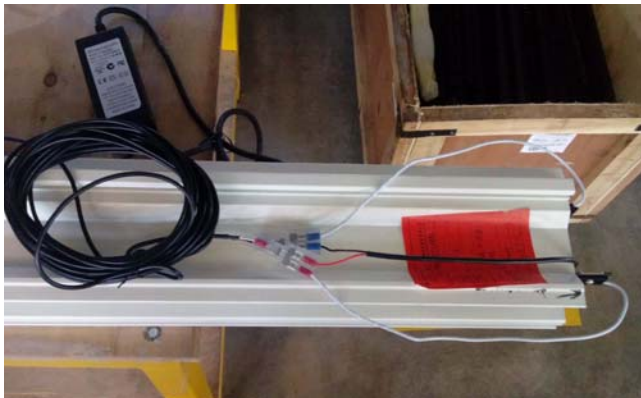

Step 10 Level seat post (if required)

If required, level the carriage seat post before installing the seat.

Procedure

It is recommended that you level the carriage seat post before installing the seat. This will ensure the seat is level when installed.

- 1 Pop off the covers at the front and back of the carriage (near the top of the carriage). To do this, carefully insert a flat blade screwdriver into the slot at the top of the cover and gently pry out to pop off the cover.
- 2 Loosen the three adjusting bolts (front and back).
- 3 Place a level on the top of the seat post and rotate the carriage plate as required to level the seat.
- 4 Tighten the three adjusting bolts (front and back).
- 5 Reinstall the carriage covers (front and back).

Figure 18

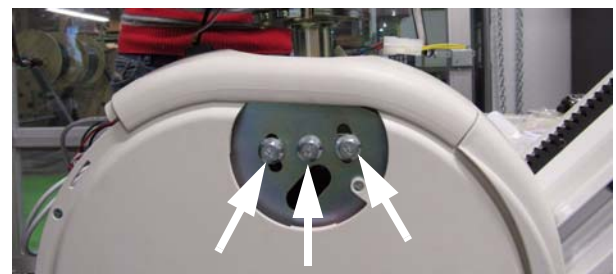
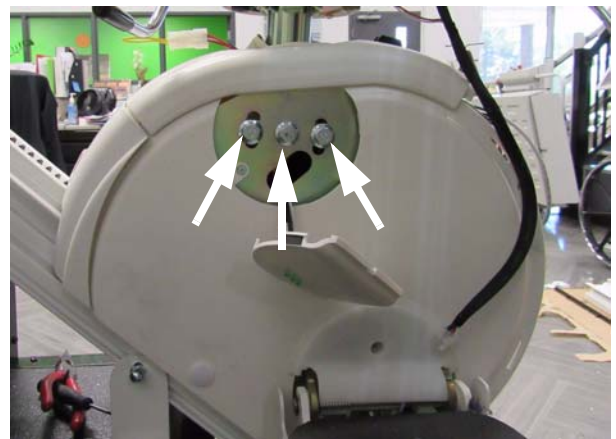

Step 11 Install seat assembly

Install the seat assembly onto the carriage.

Procedure

- 1 Before installing the seat assembly, remove the bolt from the seat plate. You will use this bolt to secure the seat plate to the carriage post plate.

Figure 19

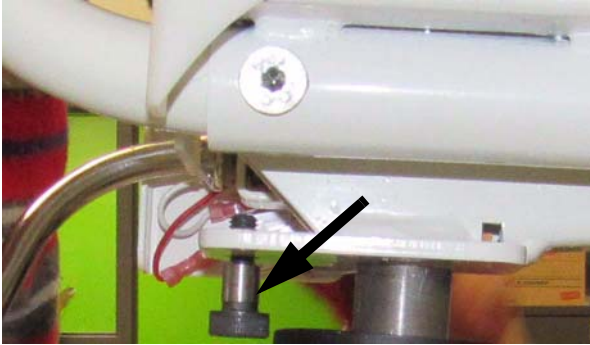

- 2 Mate the seat post into the carriage post and then install the bolt to secure the seat in place.

Figure 20

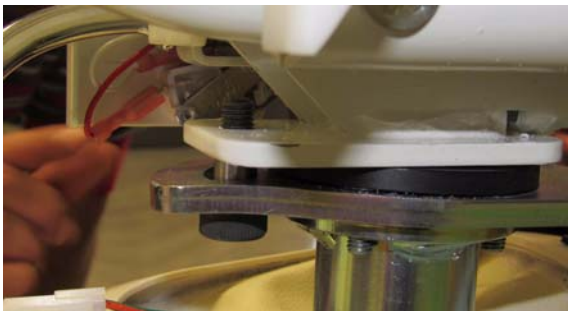

- 3 Remove the jumper plug from the carriage housing seat connector.
- 4 Make sure the key switch is turned OFF and then plug the seat cable into the seat connector on the carriage housing.
- 5 Tuck the seat connector under the velcroed cover after test the unit.

Figure 21



Step 12 Anchor rail assembly in place

Anchor the rail mounting brackets to the steps

Procedure

At this point, you can anchor the rail mounting brackets to the steps.

- 1 Ensure the rail mounting brackets are in the correct position along the length of the stairway.
- 2 Ensure there is a minimum gap of 1" (25.4 mm) from the wall to the back of the chair (or as required by code).
- 3 Drill holes in the steps as required to anchor the rail mounting brackets to the steps.
- 4 Anchor the rail mounting brackets along the stairway using the hardware provided (two bolts per bracket into the stairs).
- 5 Ensure the rail is in the final position and then tighten the acorn nuts securing the rail mounting brackets to the rail.

Figure 22

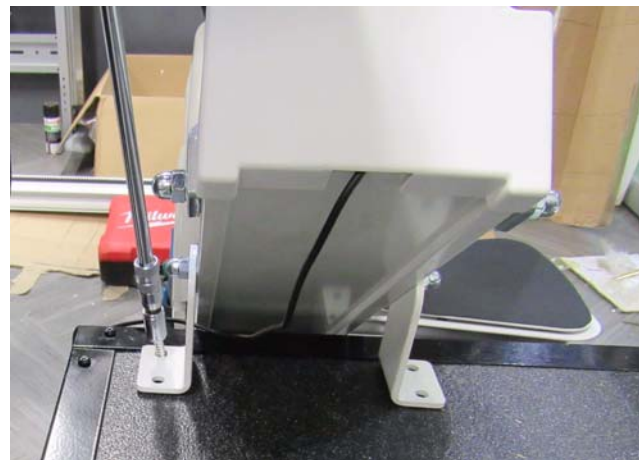

- 6 Install the top rail cap.

Figure 23



Step 13 Adjust arms (if required)

Adjust the arms if required.

Procedure

- 1 To adjust the arms in or out:
 - a. Loosen the four screws of the seat base plastic cover (two per side) and remove the plastic cover.
 - b. Loosen the two screws at each side of the arm crossbar.
 - c. Slide the arms in or out as required and then tighten the screws.
 - d. Reinstall the seat base plastic cover and secure in place with the four screws (two per side).

Figure 24



Step 14 Adjust footrest (if required)

Adjust the footrest if required.

Procedure

- 1 Remove the half-moon shaped cover above the footrest (one screw).

Figure 25



- 2 Loosen the two bolts.

Figure 26

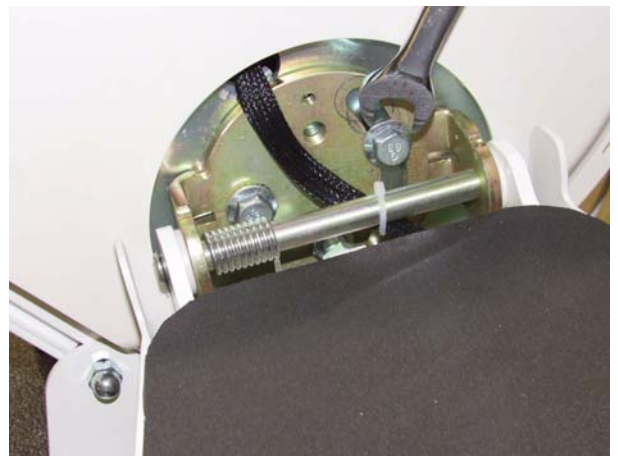

- 3 Adjust the footrest to level and then tighten the two bolts.
- 4 Reinstall the half-moon shaped cover.

Step 15 Install limit switch cams

Install the limit switch cams

Procedure

- 1 Install the bottom cam on the rail.
 - a. Run the lift to the bottom of the rail.
 - b. Position the cam so it activates the lower limit switch and stops the lift at the desired location at the bottom landing.
 - c. Mark the location of the cam on the rail. In most cases, this is as low on the rail as possible.
 - d. Secure the cam to the rail with the two self-tapping screws provided.
- 2 Install the top cam on the rail.
 - a. Run the lift to the top of the rail.
 - b. Position the cam so it activates the upper limit switch and stops the lift at the desired location at the top landing.
 - c. Mark the location of the cam on the rail. In most cases, this is as high on the rail as possible.
 - d. Secure the cam to the rail with the two self-tapping screws provided.

Figure 27



Step 16 Install mechanical stops

Install the mechanical stops at the top of the rail.

Procedure

There are two mechanical stops – one for the front of the rail and one for the back of the rail. The purpose of a mechanical stop is to stop the carriage from running off the top of the rail.

- 1 Run the carriage up to the desired position at the top of the stairs.
- 2 From the top of the rail, slide one T-bolt into the lower slots at the front and back of the rail.
- 3 With the carriage at the desired top position, install the mechanical stops 1" (25 mm) above the carriage rollers and secure them to the T-bolts in the rail slots using the acorn nuts provided.

Figure 28

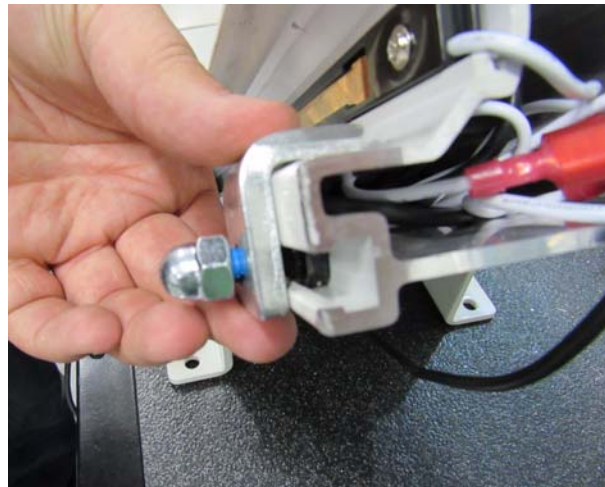

Step 17 Mount charger

Mount the charger on the wall at the top or bottom of the stairway.

Procedure

- 1 Mount the charger on the wall at the top or bottom of the stairway, as desired.
- 2 Make sure the key switch is turned OFF and then plug the charger into a household wall outlet.

Figure 29



Charger

Step 18 Check installation, lubricate and clean

Check the installation, lubricate the rack teeth and clean off the charging strips.

Procedure

- 1 Verify that all electrical connections have been made.
- 2 Verify that all mechanical components are installed properly and that all hardware is firmly tightened.
- 3 Check that all rail mounting brackets are stable and the mounting screws are firmly tightened.
- 4 Using the tube of grease provided in the chair box, lightly lubricate the teeth along the length of the rack. This will allow the carriage to travel smoothly.

Figure 30



- 5 Clean the rail of any fingerprints or grease; DO NOT use corrosive cleaners. Be sure to wipe down the charging strips after cleaning the rail; use a soft cloth.

Step 19 Test operation

Test the operation of the stairlift.

Procedure

- 1 Check all controls.
 - a. Verify that the UP/DOWN toggle switch on the right arm is functioning properly. Hold the switch to operate.
 - b. Verify that the remote control CALL/SEND units are functioning properly. Press and hold the up or down arrow button to operate.
 - c. Verify that the key switch (under the right arm) and the ON/OFF switch (on top of the carriage) are functioning properly.
 - d. Check the operation of the optional emergency STOP button (if supplied).
- 2 Verify that the seat, armrests and footrest fold up properly.
- 3 Check that the seat swivel handle is functioning properly and locks in the riding position.
- 4 Ensure that you can fasten and unfasten the seat belt and that it retracts properly.
- 5 Check that the footrest edge and underpan sensors are functioning properly. The stairlift should stop when it contacts an obstacle.
- 6 Check that the carriage edge sensors are functioning properly. The stairlift should stop when it contacts an obstacle.
- 7 Check the operation of the limit switches. The upper and lower limit switches should stop the lift when it reaches the top or bottom of the stairway. The mechanical stops at the top of the rail should stop the lift in an over-travel situation.
- 8 Check the operation of the swivel seat safety switch. The switch should prevent the stairlift from running if the seat is not locked in the riding position.

Step 20 Manual emergency operation

If necessary, you can operate the lift manually using the manual operation tool.

Procedure

The stairlift can be moved manually using the supplied manual operation tool (handwheel).

Figure 31



- 1 Turn main power off.
- 2 Remove the access cover on the lower side of the unit. To do this, place a flat blade screwdriver carefully under the corner of the cover and gently pry out to pop the cover off.
- 3 Fit the shaft of the manual operation tool onto the motor output shaft. The shaft is located below the battery tray in the carriage (circled below).

Figure 32

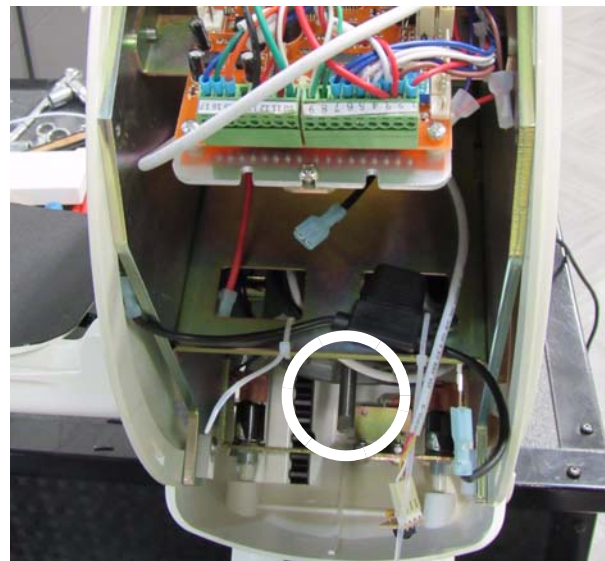

- 4 For a left-hand unit, turn the handle clockwise for the unit to travel up the stairs and counter-clockwise for the unit to travel down the stairs. Reverse the direction of turning the handle for a right-hand unit.
- 5 When movement of the carriage is complete, resolve the issue that caused the unit to stop and then reinstall the cover.

Step 21**Before leaving job site**

Before leaving the job site, make sure the work area is clean and the lift is safe and operational.

Procedure

- 1 Clean up the work area.
- 2 Explain the operation of the stairlift to the customer.
- 3 Assist the customer on an orientation ride.
- 4 Provide a copy of the Owner's Manual and Warranty to the customer. Record all required details per the Owner's Manual.

Appendix A

Reference Information

Diagnostic LEDs (on carriage front panel)

There are three LEDs located on the carriage front panel as shown below.

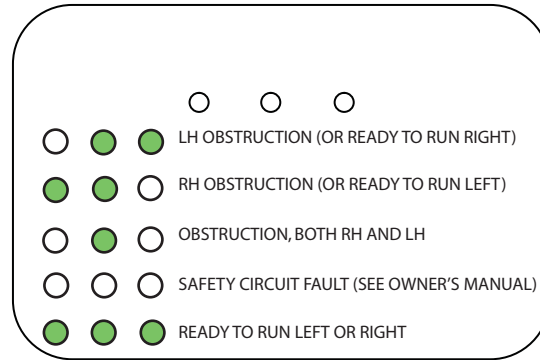

LED Status

LEDs	Meaning
Middle and right LEDs on	Left-hand obstruction (or ready to run right)
Middle and left LEDs on	Right-hand obstruction (or ready to run left)
Middle LED on	Obstruction, both right-hand and left-hand
All LEDs off	Safety circuit fault
All LEDs on	Ready to run left or right

PCB layout

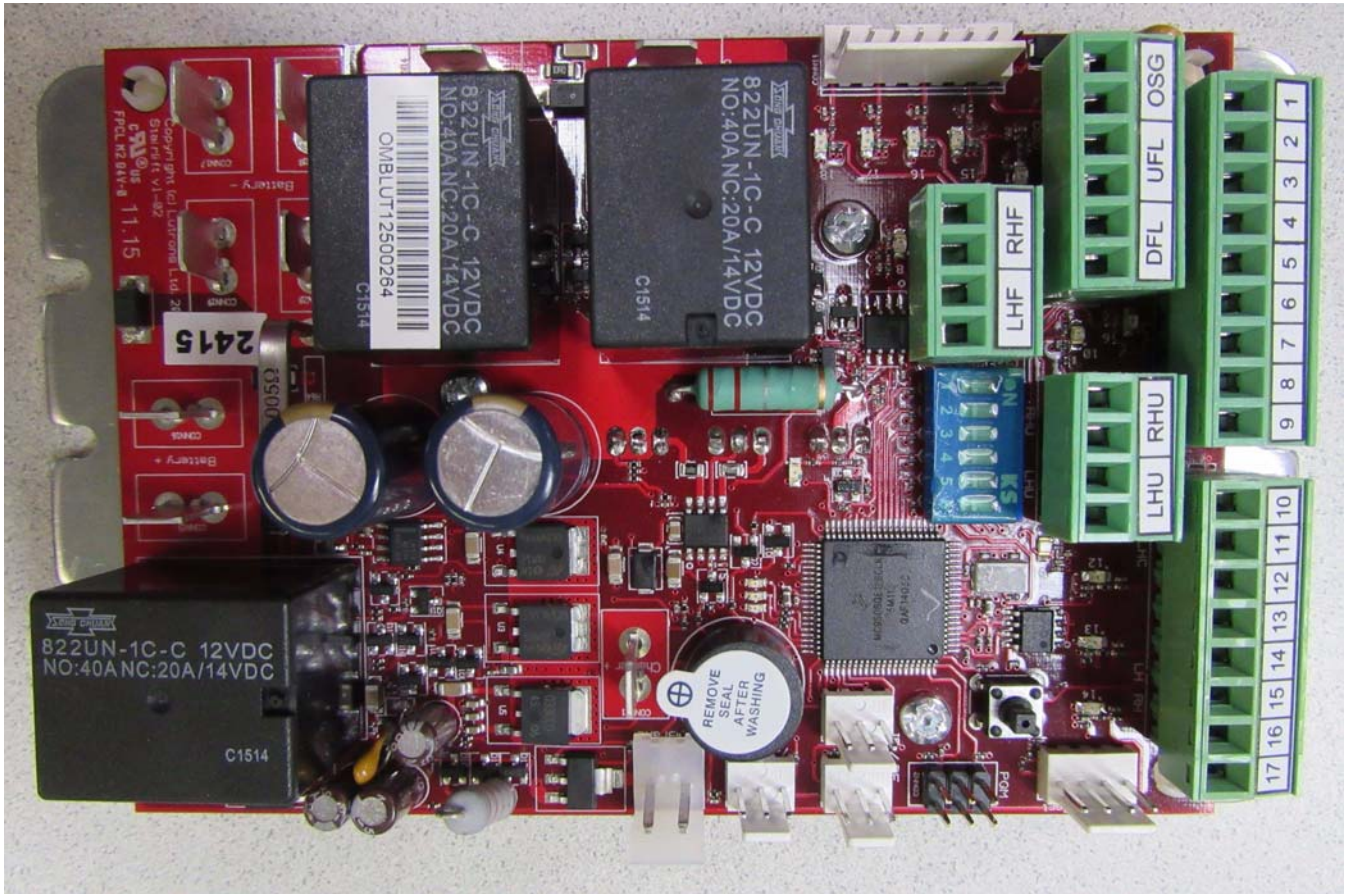

DIP switch settings

Switch	State	Function
1	ON	Right hand unit
	OFF	Left hand unit
2	ON	Brake installed
	OFF	Brake not installed
3	ON	Current limit high
	OFF	Current limit low
4	ON	Soft start/stop (when charge detected at cam)
	OFF	No soft start/stop
5	ON	Not used
	OFF	
6	ON	Silent mode (no buzzer)
	OFF	Normal mode (buzzer)

PCB wiring diagram

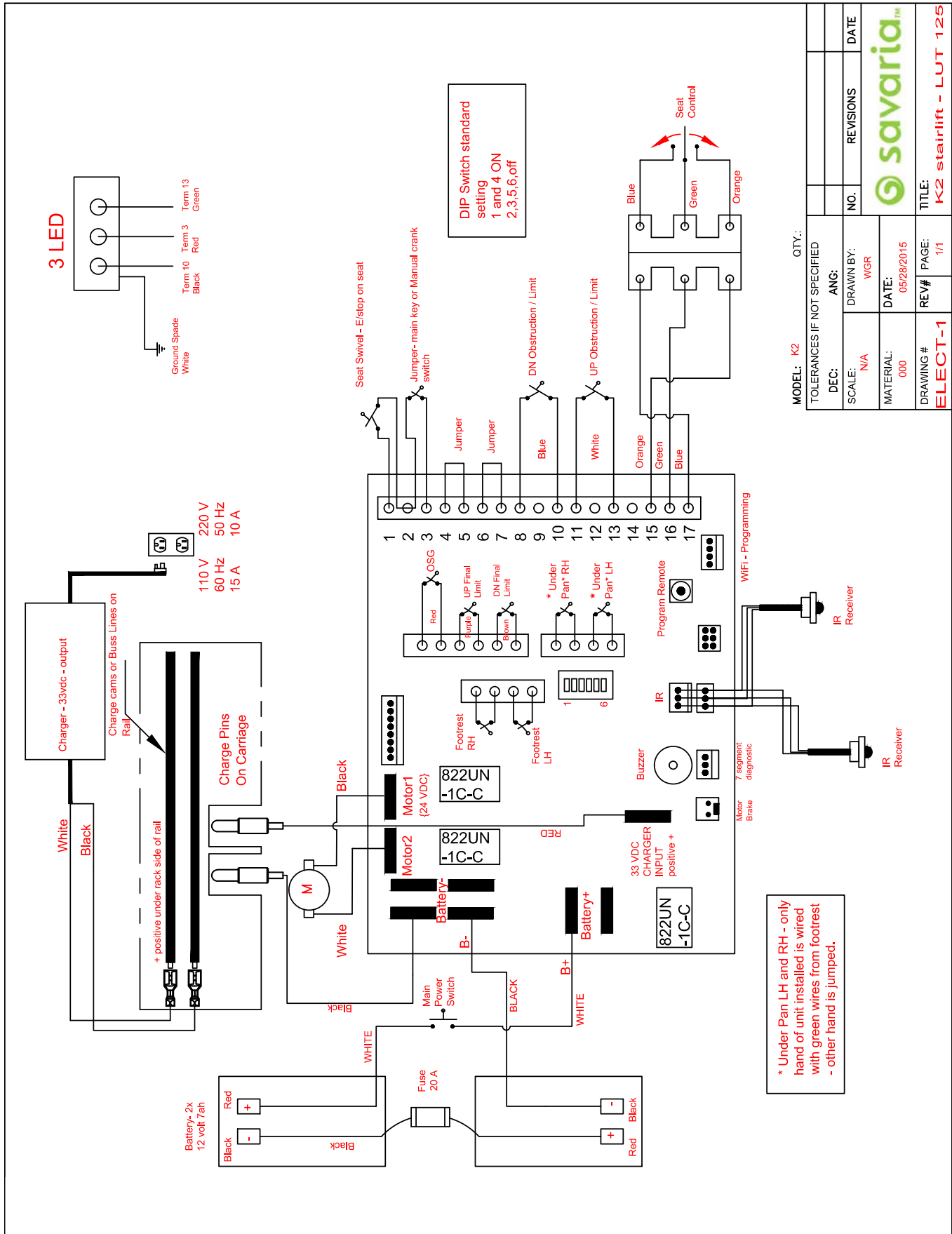

MODEL: K2	QTY.:
TOLERANCES IF NOT SPECIFIED	
DEC:	ANG:
SCALE: N/A	DRAWN BY: WGR
MATERIAL: 000	DATE: 05/28/2015
DRAWING #	REV#
ELECT-1	1/1
TITLE: K2 stairlift - LUT 125	

Appendix B

Maintenance

Maintenance Schedule

Verification by owner	Frequency
Check that the swivel seat switch is working. Ensure the unit will not travel until the swivel seat is locked in the riding position.	Every 3 months
Check that the footrest and carriage sensors are working. Ensure the unit stops when it contacts an obstacle.	Every 3 months
Check that the emergency stop button is working. Ensure the unit stops immediately when the button is pressed.	Every 3 months
Verification by technician	Frequency
Check the operation of the limit switches. Ensure the unit stops at the required position at the top and bottom of the stairway.	Every 6 months
Check the operation of the overspeed brake.	Every 6 months
Lubricate the rollers using white lithium grease.	As required
Lubricate the seat swivel system using wheel bearing grease.	As required

