



Installation Manual



≡ **ALPHA** ≡
Chair - stairlift
CE

CONTENTS

OBSERVE THE FOLLOWING POINTS BEFORE INSTALLATION!3

INSTALLATION OF THE RAILS4

INSTALLATION OF THE DRIVE UNIT ONTO THE RAIL.....6

EXPLANATION OF UPPER AND LOWER TROLLEY.....8

SPEED REDUCTION LEVER (SLOWDOWN ARM) FOR CURVE SPEED9

INSTALLING OF THE CHARGING STATION/LIMIT ASSEMBLY9

OVERSPEED GOVERNOR12

SOUND INDICATION12

PROGRAMMING OF REMOTES12

BASIC TROUBLESHOOTING.....13

SWITCHES AND JUMPERS ON THE CONTROL UNIT14

LED SIGNALIZATION ON STAIRLIFT CONTROL UNIT.....16

POSITION SWITCHES ON CHAIR STAIRLIFT19

MENU.....20

Menu activation20

Menu structure:21

ERROR AND OPERATION DIAGNOSTIC ON THE DISPLAY27

OPTION: AUTOMATIC SWIVEL SEAT.....28

Observe the following points before installation!

Installation teams must have a general knowledge in:

- working on electric controls
- basic mechanical engineering and providing adequate fixation of the rails and pillars
- reading and understanding circuit diagrams and wiring schematics

The following points are necessary for the installation:

- Have a complete tool kit on hand for mechanical and electrical works
- Check beforehand what fixing materials (screws, anchor bolts, adhesives) are required for the proper fixing of the rails to the wall or the pillars to the floor. These materials are not included in the delivery! The installation company is responsible for the fixing of the rail to the wall or the pillars to the floor/steps!
- Check the packages for shipping damage and missing parts before bringing the lift to the site. Take pictures of damaged parts as soon as these are discovered to provide proof for warranty claims.
- A team of 1 qualified technician and an assisting technician is necessary to install the lift.

Beginning the Installation

Bring the platform to the upper landing before fixing the rails in order to prevent damage to the rail and platform during transport on the staircase! The platform can only be engaged from the upper end of the rail.

The following tools will be required to finish the installation successfully:

- A complete toolset for mechanical and electrical works
- Voltmeter
- Drilling machines
- Drills, thread cutter
- Fixing material based on on-site requirements
- Spirit level with angle indication



Installation of the rails

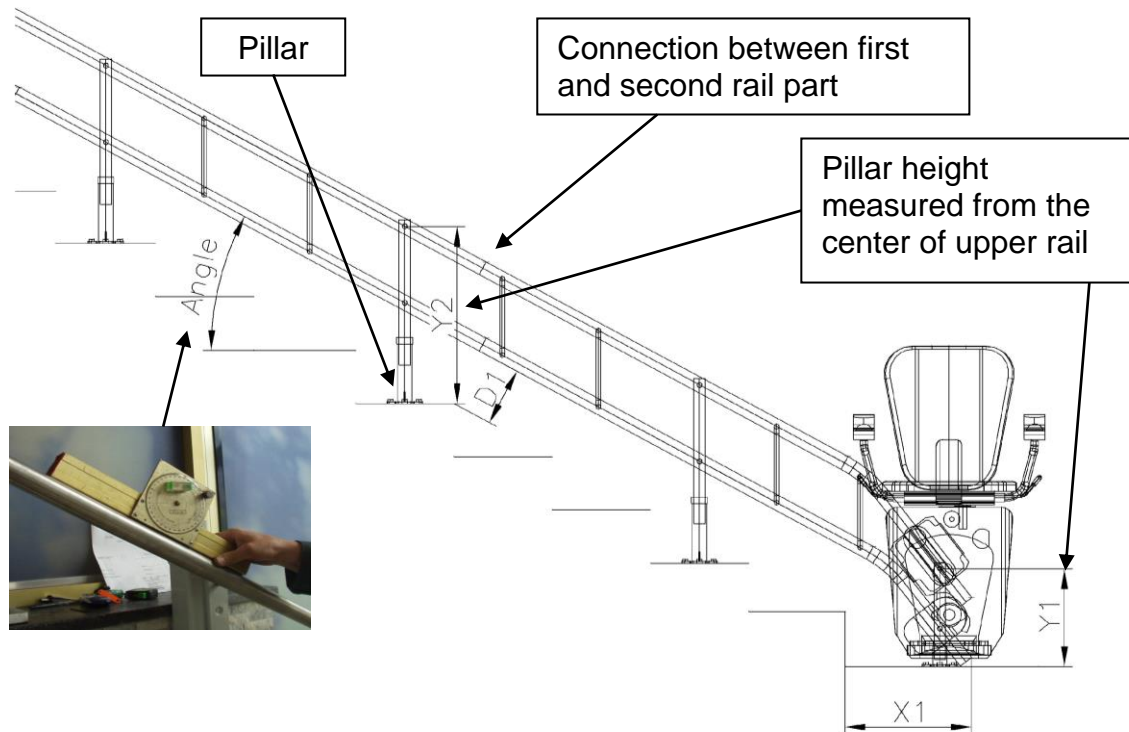

Step 1: Start fixing the rail from the bottom! Do not start installation from the top.

Add the pillar to the rail posts and place the first rail part on the staircase. Fix the post only temporarily with the worm screws. Do not fix too tight so not to leave pressure marks on the paint as you might need to change height of the post during installation.

Step 2: In order to later connect both landings stations to the charger it is necessary to insert a single phase (1x1mm²) cable into the lower tube. If the rail is short this can be done at the end of the installation. If the rail is long this should be done while combining the individual rail parts. In this case please enter the cable into the first part and then, before combining the rail part, also into the second rail part and so forth.

Step 3: Add the second rail part. Now make sure the vertical measures from the first pillars Y1 and the first pillar of the second rail part Y2 are correct. Check diagonal measure D1 measured from the step nose to the underside of the lower rail. Check also if the angle indicated in the installation drawing is respected on the installed rail.

Step 4: Make sure all pillars are vertical and also that both rail tubes are aligned vertically above each other.

Step 5: Fix the rail parts with the locking pin. Tighten the other pillars at the correct height with the 3 worm screws.

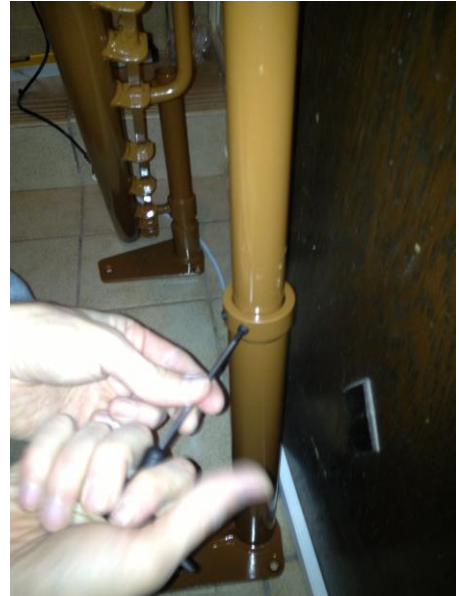

Step 6: When all rail parts are connected and all pillars are set to the correct height check again all clearance measures and the correct position of the rail according to the installation drawing.

Step 7: If all is ok fix the pillars to the steps. Use appropriate fixing material according to the staircase material.

Installation of the drive unit onto the rail

Step 1: Take the box with the drive unit close to the upper end of the rail. Open the box so that the rails and trolleys are on the top of the box. Take out the drive unit and place it on the floor so that it is standing upright



Step 2: Take off the wooden plates on each side. Put the drive unit on the floor (use protection under it so not to scratch it). Then 2 people should lift the drive unit on the rails and attach the installation rails to the top of the installed rail on the staircase. Then slide the drive unit down until it reaches the top of the installed rail. Use the handwheel to drive the unit onto the installed rail so that the lower rail passes entirely through the lower trolley.



Step 3: Take of the side and front plastic covers. Then put the chair into the fixation and fix and lock it with the screw and washer from inside the drive unit.

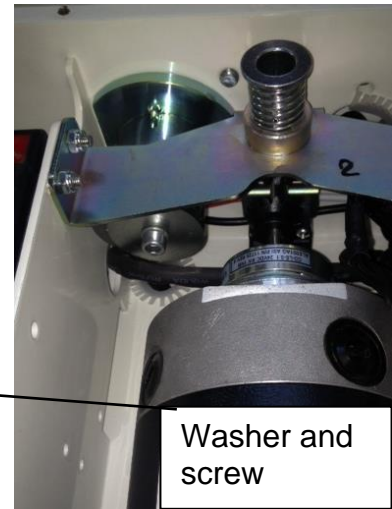

Step 4: Use cable ties to fix the connection cable between from the chair to the drive unit. Makes sure the seat can freely rotate with the cable getting twisted or squeezed. Before fixing the cables rotate the seat to the maximum, then fix cables in place and rotate back and forth to see if the cable moves freely.



Step 5: Now drive the unit down and up to check if the seat passes all steps and if the clearance is ok.

Explanation of upper and lower trolley

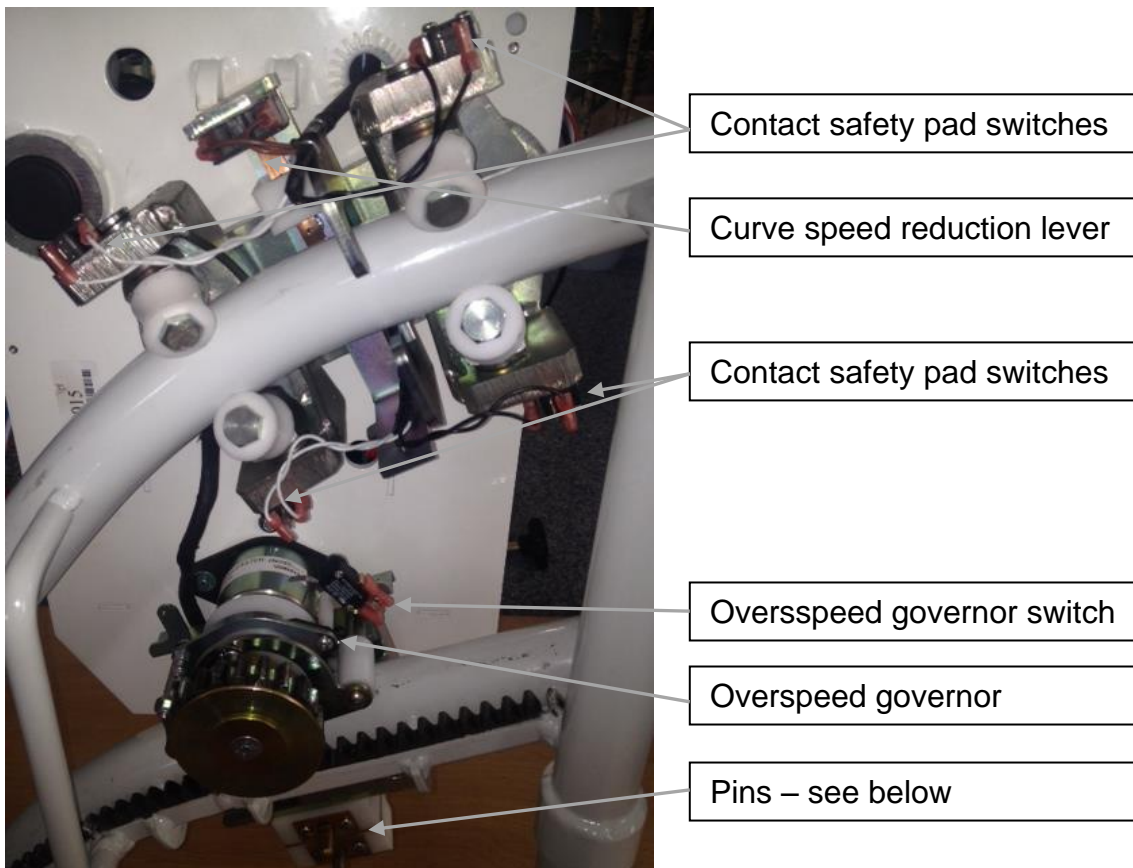

The lower pin is the ultimate stop pin. This activates the safety switch at the end of the rail (in case the normal stop would not work). The upper pin is responsible for taking the positive charging current and at the same time activates a slow down switch when at hitting the landing station charging cams. On an intermediate stop assembly this pin is pressed further inside and then additionally activates the intermediate stop switch. This only happens on intermediate stops, not on end stops.

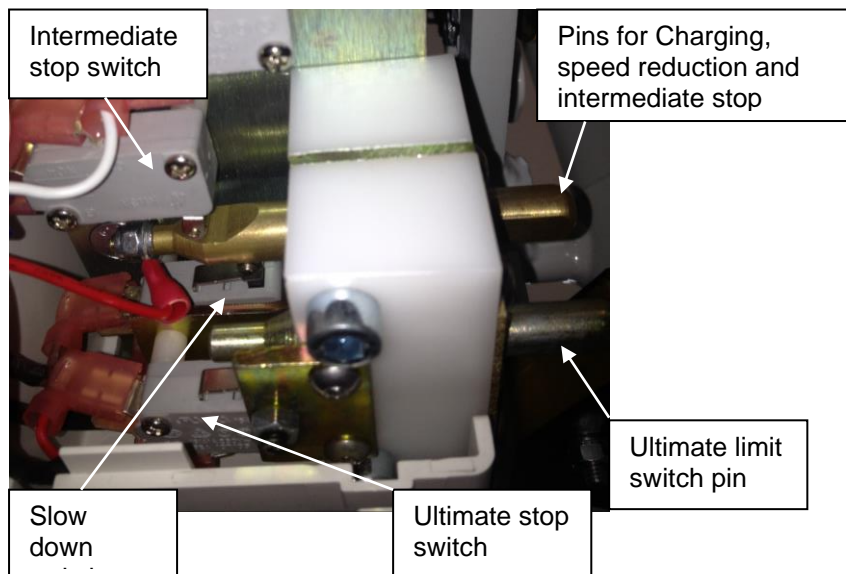
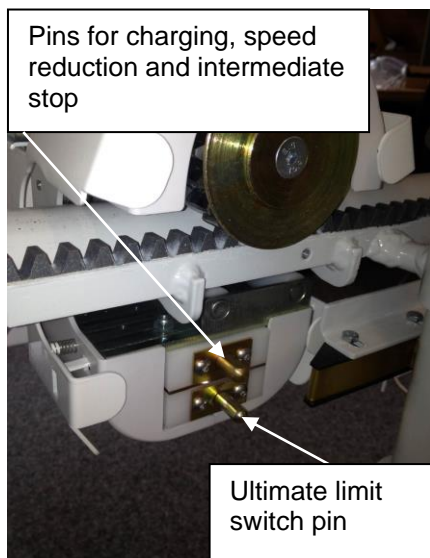

Speed reduction lever (slowdown arm) for curve speed

Take off the top metal cover of the upper trolley and take out a foam cube that is located between the speed control pin and the back of the trolley. This foam is there so the speed reduction lever cannot get bent when the drive unit is put onto the rails at the start of the installation. Then check if the unit slows down correctly in the curves and drives fast in the straight sections.



The lever is activated by the rail. When the lift drives into a curve the rail bend presses the lever so that it activates the speed reduction switch. If the unit does not slow down correctly please bend the lever a little so that the speed reduction switch is pressed even more when the lift drives into a curve. Make sure you do not bend it so much that it drives slow also on straight sections.

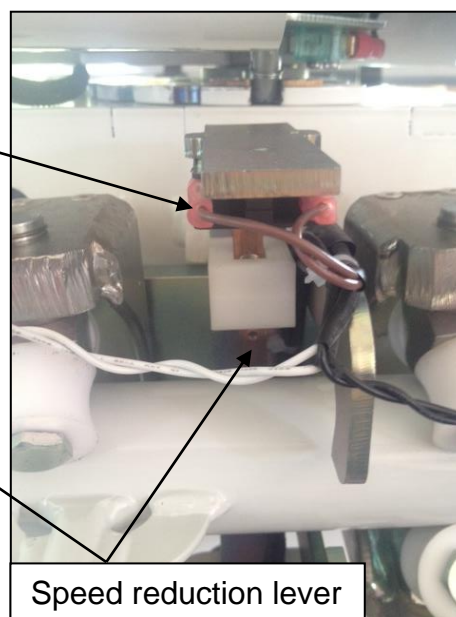
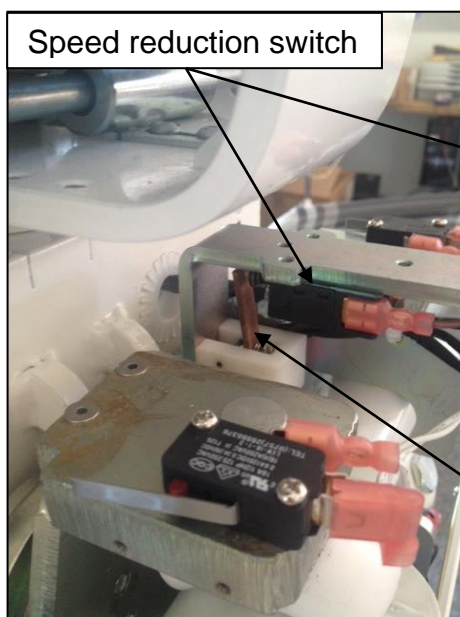

Installing of the charging station/limit assembly

The chairlift is stop when it reaches the end of the charging station by the metal pin pressing the lower carriage contact plate. Make sure the seat stops in the correct place and mark this spot for the charging station. Then fix the charging station by drilling 2 threaded holes (dimension M5) into the pipe. Fix the charger close to the upper or lower landing station, where it is most convenient. Then connect the charger to the landing stations closest to the charger. Connect the negative to the rail and the positive to the copper of the charging station.

Connect all copper plate on all charging stations with 1 cable. Run this cable in the lower tube of the rails and bring it out close to each charging station.

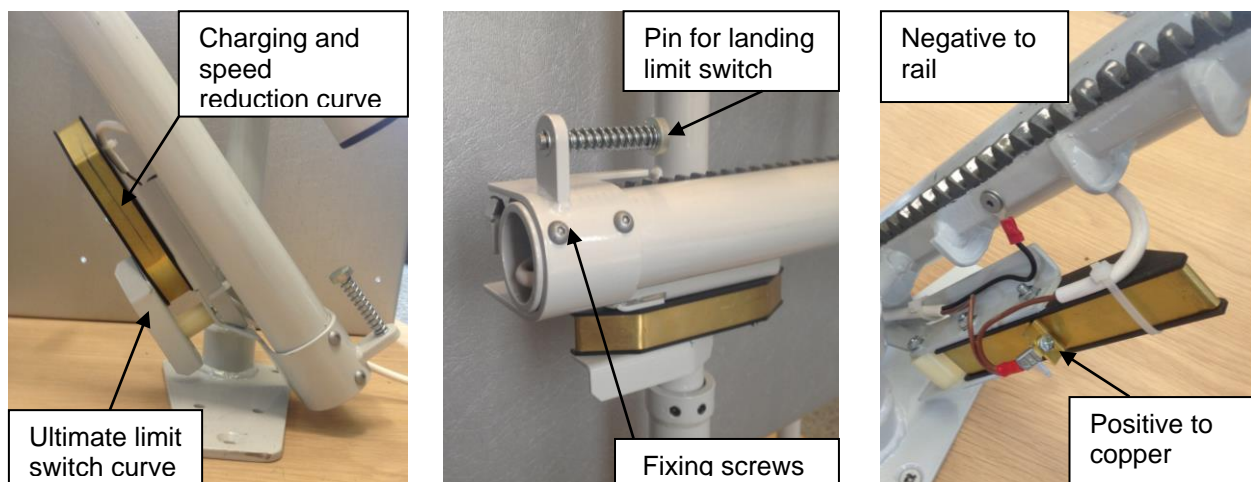

On inclined rail parts the electrical ground is transferred to the board via the rack. But in horizontal section this ground connection can be unstable. Therefore, in case of a horizontal stop or an intermediate landing it is necessary to add a copper plate onto the upper tube. This copper plate ensures the electrical ground connection to the stairlift board.

After the charging stations has been fixed in its final position, please run the seat in this stop and check where the lever for the speed reduction in curves is positioned when the stairlift is in the stop position.

The copper plate now needs to be placed on this exact spot. Drill and tap the upper tube to fix the copper plate.

When the lift is in the stop position the speed reduction lever is pressing against this copper plate in the upper stop.

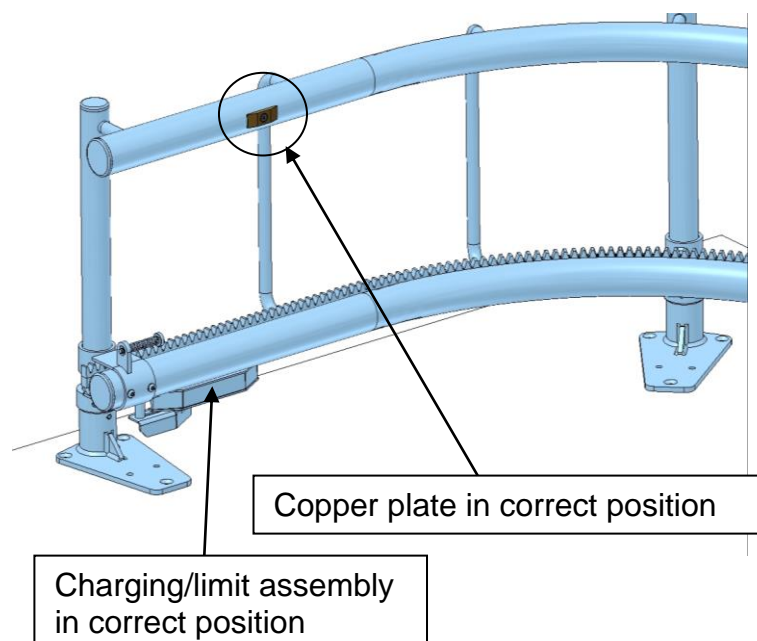

Checks:

- Check the correct function of all safety contact pads. These are located on the bottom and top trolley, on the side and below the drive unit and under the footrest. These contact pads should stop the lift when pressed against the driving direction. See below:

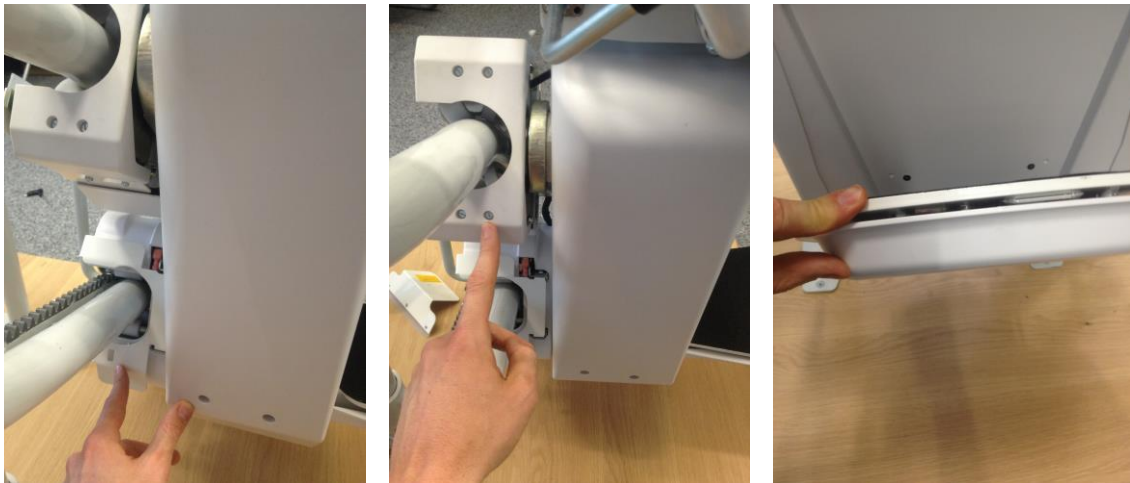

- Check the function of the seat rotation switch and the armrest switch.
- Check the function of the curve speed reduction switch/lever.
- Check the function of the landing stations speed reduction pin/switch.
- Check the function of the intermediate landing pin/switch.
- Check the function of the final stop pin/switch.
- Check the function of the landing limit switch. This is the contact switch in the safety pads of the lower trolley. Check the correct position of the stop pin that activates the safety pads in the landing assembly.
- Check the correct charging of the drive unit in the landings stations.

Overspeed governor

Explanation:

The overspeed governor is set to trip at 0,3m/s so of speed.

The tripping point is set via the length of the activation screw. Screws, pins and springs that keep the governor in place are set by the factory and sealed with paint markings.

If the spring is not properly set the overspeed governor could activate too quickly during normal run. In such a case the spring needs to be readjusted accordingly.

Pin to keep governor in place

Spring to keep governor in place

Activation screw

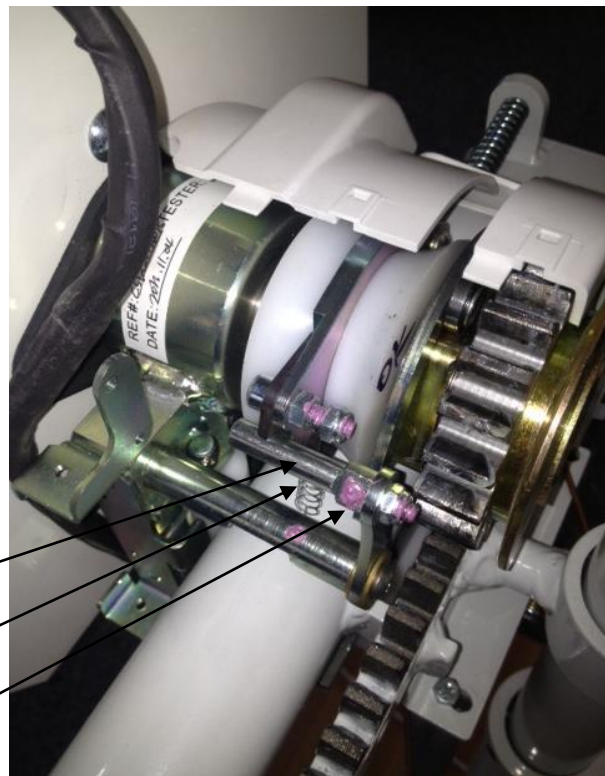

Sound indication

- If the lift is parked outside a charging station (not charging!) it will make a beep sound after 5 seconds. The beep sound will appear every second with a 0,3 second long signal.
- If the battery voltage is getting low a beep sound will appear every 2,5 seconds with a 2 second long signal.

Programming of remotes

The remotes come already programmed. In case you need to programme new remotes press the programming button on the main board for 2 seconds. The LED on the remote receiver should start flashing fast (every 0,5 seconds instead of every second). Then press the up and down button of the remote sender at the same time.

First the LED on the sender flashes orange, then it should show an orange light and finally show a green light. Now you can programme a second remote sender by again pressing both buttons at the same time.

When finished press again the programming button on the main board for 2 seconds. The LED on the receiver board should return to flash normally (every second)

Basic Troubleshooting

Next to the main power switch are 3 LEDs. The left and the right LED indicate the directional obstruction sensors on the drive unit and trolleys. The middle LED indicates the safety circuit. If all 3 LEDs are turned off the safety circuit is open.

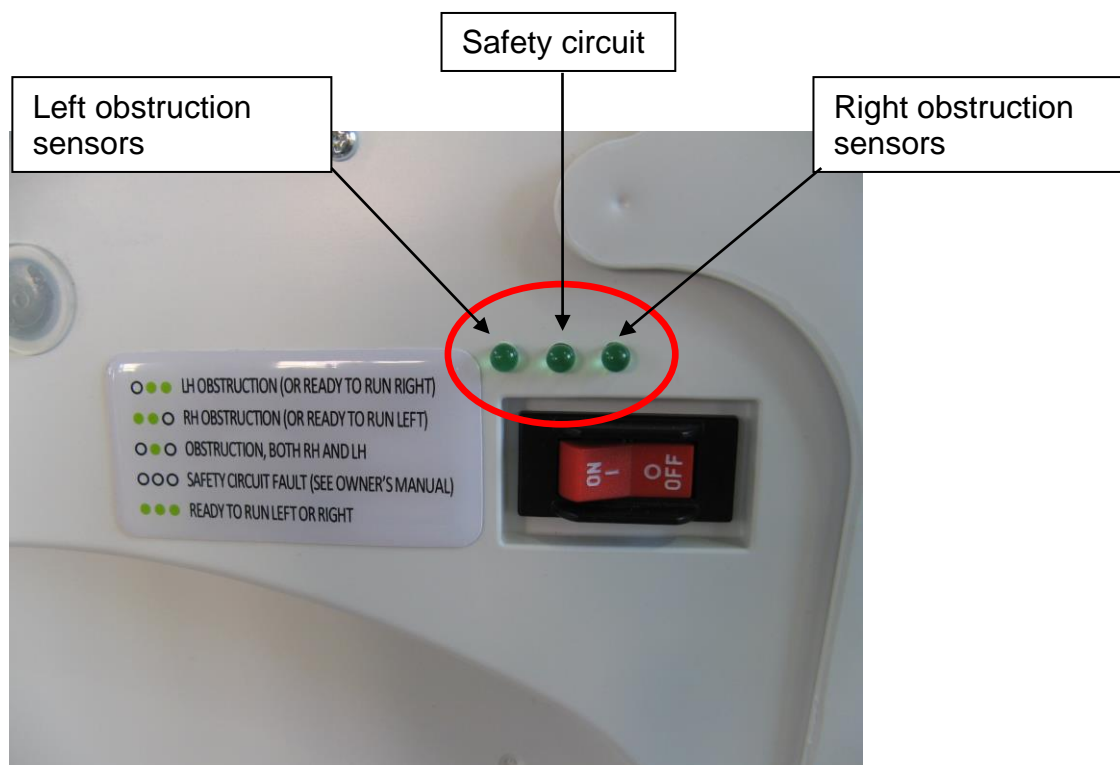

The safety circuit consists of the following switches:

- Overspeed governor switch S10
- Seat rotation switch SR2
- Ultimate limit switch S22
- Handwheel switch SA5

The directional obstructions sensors consist of the following switches (left/right):

- Upper trolley S13/S12
- Lower trolley S27/S28
- Lateral drive unit SK-1/SK-2
- Footrest (directional) EK-R/EK-L
- Footrest and underside of drive unit (sensitive only in down direction) S17

The following pages allow for advanced trouble shooting. This can be done by observing the LED on the board and/or by using the attachable display for parameter setting and detailed error code reading.

Switches and jumpers on the control unit

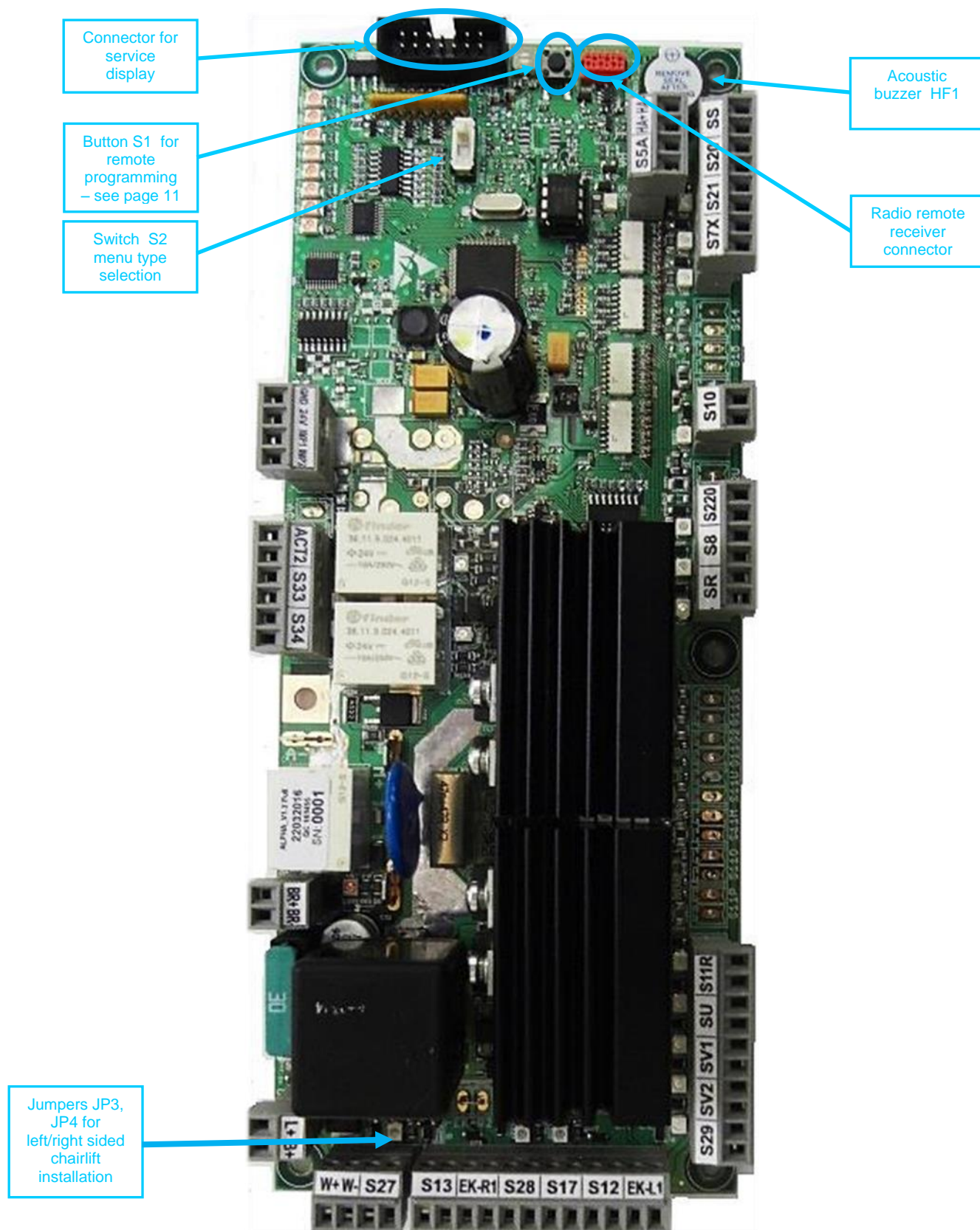

S2 switch

This switch selects between user/service menu types. For the detailed description see chapter 0 Menu.

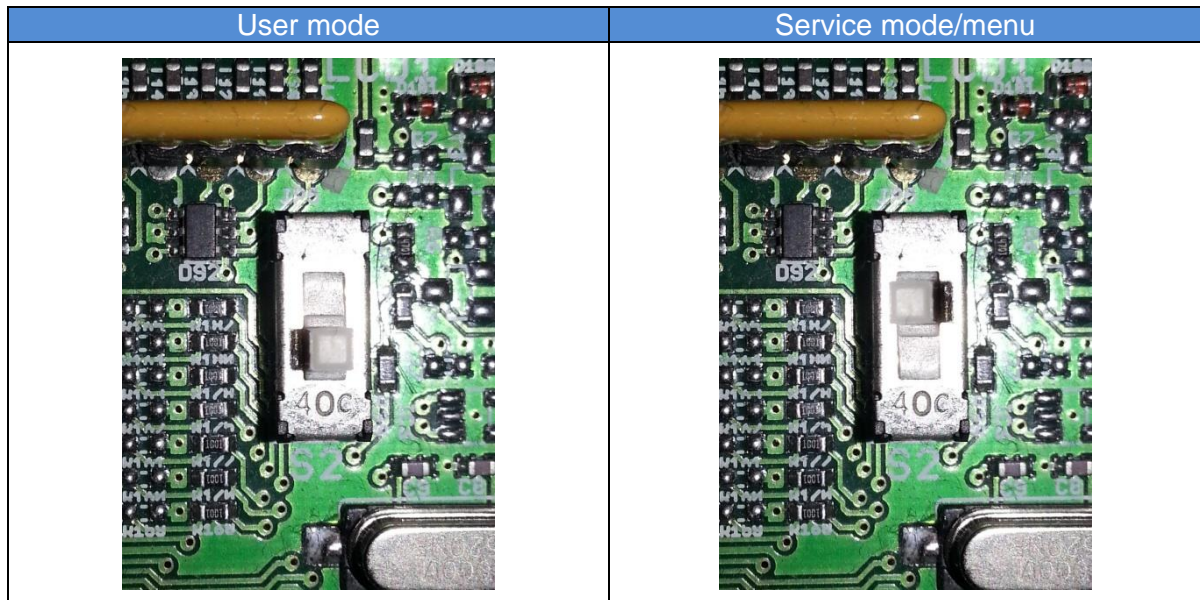

WARNING: After the platform installation and setting all service menu parameters, push the switch S2 to the position for user menu!!!

Jumpers JP3 and JP4

Jumpers JP3 and JP4 must be set properly according to left sided and right sided installation.

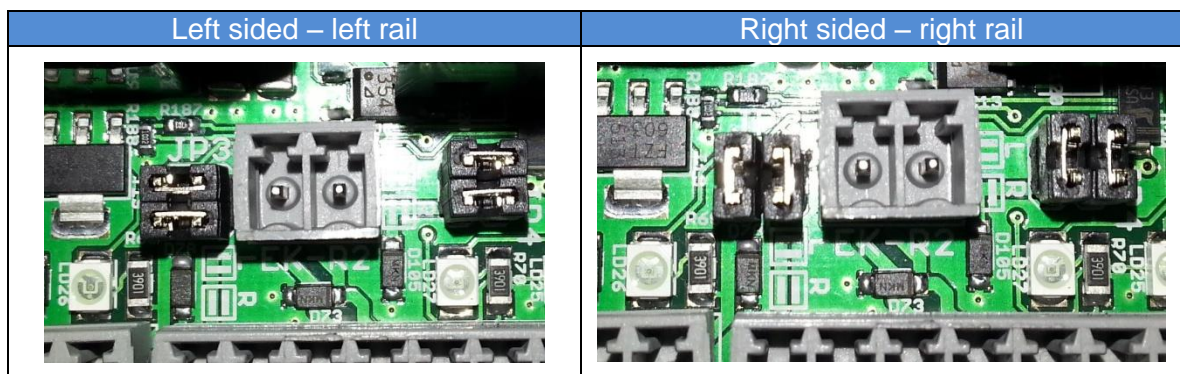

CAUTION: Proper jumper setting is absolutely necessary for the correct and safe function – safety elements in the drive direction.

LED signalization on stairlift control unit

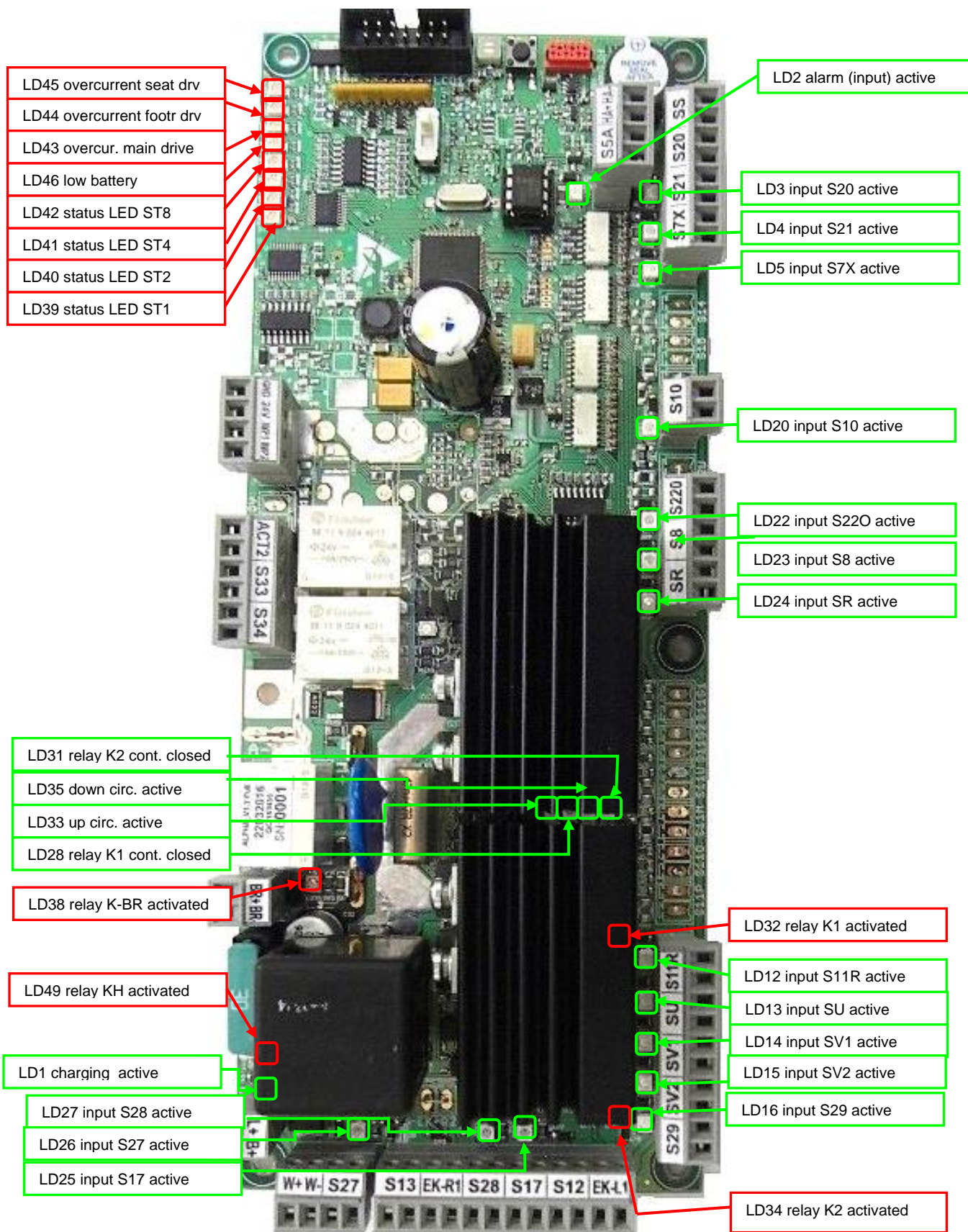

Name	Color	Function
LD1	green	Lights when battery charging is active
LD2	green	Lights when alarm input is activated
LD3	green	Lights when platform controller button UP is active
LD4	green	Lights when platform controller button DOWN is active
LD5	green	S7X; goes off after pushing the STOP-button
LD12	green	S11R; Lights when armrest is up
LD13	green	SU; Lights when the platform is overloaded
LD14	green	SV1; Goes off when platf. enters slowdown before stop
LD15	green	SV2; Goes off when platf. enters slowdown in curve
LD16	green	S29; Goes off when platf. is in MIDDLE STATION
LD20	green	S10; Goes off when overspeed detected and safety gear activated
LD22	green	S220; Goes off when ultimate limit switch (up/down) opens
LD23	green	S8; Goes off while blocking (manual drive override)
LD24	green	SR; Lights when seat is in closed (locked) position
LD25	green	S17; Goes off when safety bottom activates (press)
LD26	green	S27; Goes off when upper limit switch is activated
LD27	green	S28, S17; Goes off when lower limit switch or sensitive bottom is activated
LD28	green	Relay K1; Lights when relay K1 contact is closed (up direction)
LD31	green	Relay K2; Lights when relay K2 contact is closed (down direction)
LD32	red	Relay K1; Lights when relay K1 is activated (drive up)
LD33	green	Goes off when lateral contact or pad switches in up direction are opened i.e. S12 or EK-L for right-sided rail is opened or S13 or EK-R for left-sided rail is opened
LD34	red	Relay K2; Lights when relay K2 is activated (drive down)
LD35	green	Goes off when lateral contact or pad switches in down direction are opened i.e. S12 or EK-L for left-sided rail is opened or S13 or EK-R for right-sided rail is opened
LD38	red	Relay K-BR; Lights when brake relay is activated (unbraked)
LD39	red	Status LED ST1; see the table in the following chapter
LD40	red	Status LED ST2; see the table in the following chapter
LD41	red	Status LED ST4; see the table in the following chapter
LD42	red	Status LED ST8; see the table in the following chapter
LD43	red	Lights when overcurrent is detected on the main drive 1
LD44	red	Lights when overcurrent is detected on the drive 2 – automatic footrest actuator
LD45	red	Lights when overcurrent is detected on the drive 3 – automatic seat rotation
LD46	red	Lights when battery voltage is low
LD47	red	Lights when quadrature input 2 is activated (not used for Alpha)

Name	Color		Function
LD48	red		Lights when quadrature input 1 is activated (not used for Alpha)
LD49	red		Relay KH; Lights when main relay is activated

Status LED

In the following table there are all status LED combinations described. These LEDs and the table are useful especially when no display is available and the service worker needs to know the state of the control unit.

ST	1 (LD39)	2 (LD40)	4 (LD41)	8 (LD42)	Description
1	x				drive up by seat controller S20
2		x			drive down by seat controller S21
3			x		drive up by remote RF controllers
4				x	drive down remote RF controllers
5	x		x		rotation/closing of seat
6	x			x	rotation/opening of seat
7	x	x			stairlift is in a station and being charged
8	x	x	x		stairlift out of station and not charged
9	x	x	x	x	error

Position switches on chair stairlift

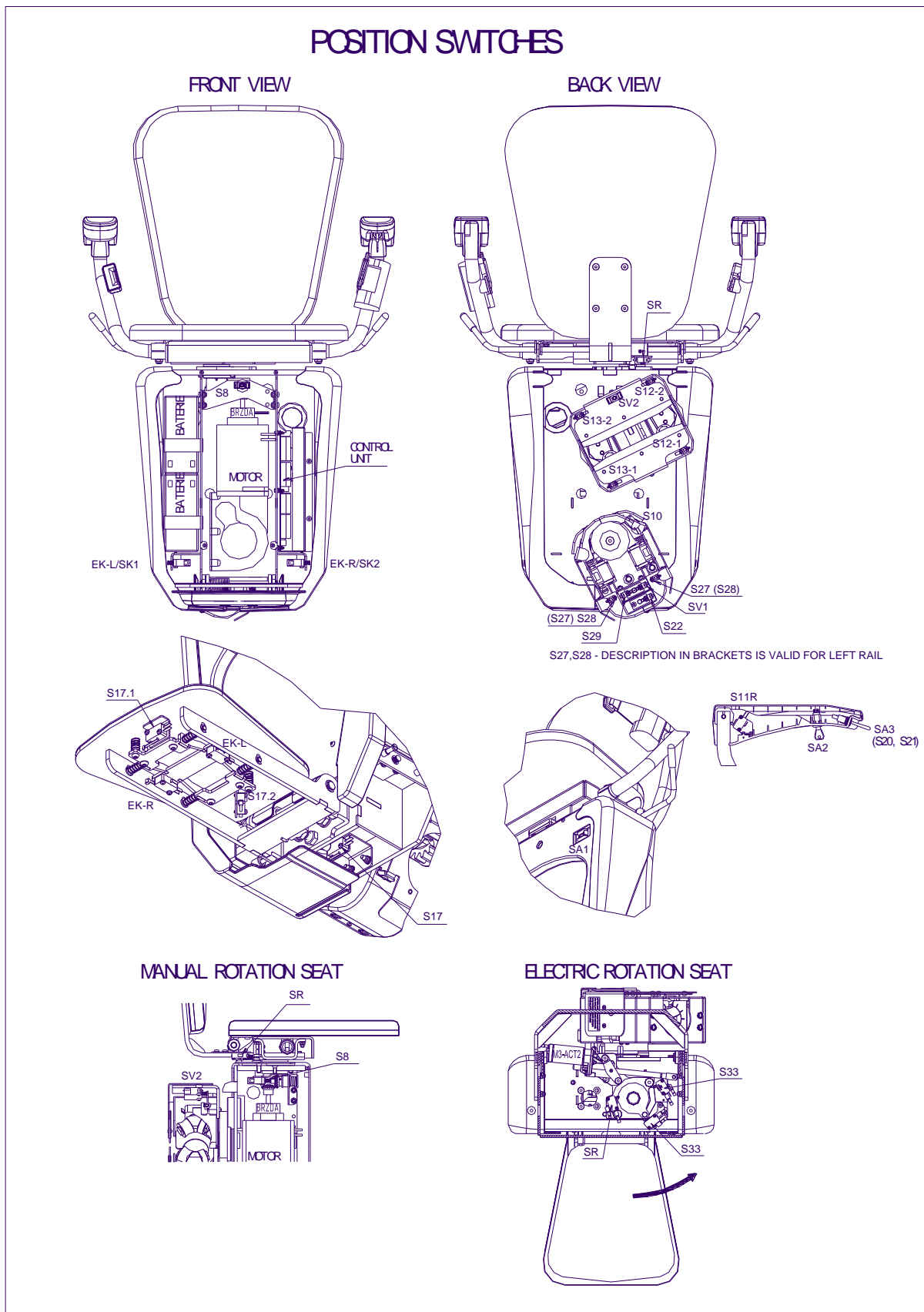

Menu

For detailed service operation a pluggable display allows to access of the Service Mode/Menu. Here basic parameter can be changed.

Service mode with the information about the battery voltage and the current flowing into the motor/actuator:



WARNING: After installation and setting of all the parameters, set the switch S2 back to user's mode. Otherwise, after the chair stairlift reaches the final station the entrance into the menu can be blocked – and whole control system can be blocked as well.

Menu activation

1. After attaching the display, set switch S2 (see page 14/15).
2. The chair stairlift must be in the lower station.
3. If the stairlift is in the lower station press drive down on the joystick for a time longer than 5 sec.
4. Now the menu is activated:



Arrow highlights currently selected menu item

5. Now you can switch between main menu points by pressing the joystick in the “up” direction. To confirm a menu item (enter in submenu of this item) or confirm a value inside a sub menu, press the joystick in down direction. The active item is always on the first row of the display – marked with an arrow.
 - a. Change item : Press UP
 - b. Confirm item: Press DOWN
6. To exit the menu it is necessary to confirm the item “back” by pressing the “down” direction on the joystick.

Menu structure:

Menu item	Description
Device info	This first item shows basic information about the device – version of HW, SW and serial number
Language	Display language can be set via this item
Factory number	This item can store custom factory number.
Error	Shows list of recorded errors, allows also to delete this list.
Ack. error	If activated, clears current error. This is possible only in a station.
Operation-time	This item shows operation time and also allows to clear it.
Factory default	Activation of this item restores all parameters to factory default.
Alert output	Allows setting of used warning elements and frequency of signalization.
Radio version	Allows radio module version setting.
Motor config.	Allows setting of all parameters for motor and actuators, speed limits for the chair stairlift and seat rotation.
Seat rotation	Allows setting manual or electric rotation of the seat and sets for automatic rotation in which station the seat rotates.
Options	Allows to set platform's special functions

In the following paragraphs some of menu items will be described. Factory default settings are underlined in following lists. These settings can be restored by resetting system to factory default settings. See chapter 0 **Menu** .

Device inf

First row shows the type of device Alpha new and the version of HW and SW. Second row shows factory number – the number which is saved in menu as factory number.

Language

Menu item	Value	Name	Description
Language	CZE	Czech	One of these can be selected
	<u>ENG</u>	<u>English</u>	
	GER	German	
	ESP	Spanish	
	FRA	French	
	PL	Polish	

Factory number

A factory or identification number can be set by this menu item (5 digits). Command for the movement up can change current digit. The currently edited digit is highlighted. Command for the movement down can move onto the next digit.

Errors

Menu item	Value	Name	Description
Error list	Fxxx č/26 h:m:s	-	Shows list of stored errors. First row shows code number of error Fxxx. Second row shows current operation time when error appeared.
Clear errors	Sure? YES	-	By activation and selecting YES all stored errors will be purged from the list. CAUTION: List of errors can be deleted by the authorized technician only.

Acknowledge error

If the menu item is active, all errors that occurred are acknowledged. Errors which must be acknowledged by service men are mentioned in the table of errors.

Operation time

Menu item	Value	Name	Description
Show op-time	h:m:s	-	This item shows current operation time in hrs:min:sec format
Reset op-time	Sure? YES	-	By activation and selecting YES operation time counter is cleared. CAUTION: Operation time counter can be cleared by the authorized technician only.

Factory default

Activation of this item restores all parameters to factory default. Factory default settings are underlined in lists.

Movement signalization – signal output

Menu item	Value	Name	Description
Signal ON/OFF	<u>OFF</u>	<u>Signalization off</u>	This parameter enables/disables outside signalization (output on clips W+, W-) for example LED-signalization
	ON	Signalization on during movement on the rail	
Frequency	1...8	fast→slow	Sets signal frequency. Applies for both buzzer and WARN output. 1 → Fast blinking/beeping 8 → Slow blinking/beeping 9 → permanent light/tone
	9	Permanent tone	
Buzzer ON/OFF	<u>OFF</u>	<u>Buzzer off</u>	This parameter sets presence of buzzer tone during the platform movement.
	ON1	Buzzer always on	
	ON2	Buzzer on during movement only with RF controllers	

Radio controller version

Menu item	Value	Name	Description
Radio version	<u>1</u>	<u>TX-OMDE-V-01</u> <u>(Schmidiger)</u>	Allows radio module version setting.
	2	Reserve for other (future) type of radio controller	

Motor configuration

Menu item	Value	Name	Description
Overcurrent threshold settings			
Main drive	15...40 <u>20</u>	A	Sets overcurrent threshold for the main motor. After exceeding this threshold motor stops, "DRIVE MOTOR CURRENT LIMIT" error is shown on the display and signaled by LEDs on CU board.
Actuator 1 (footrest movement)	0,2...1,0 <u>0,3</u>	A	Sets overcurrent threshold for footrest movement. After exceeding this threshold actuator stops, "ACT1 CURRENT LIMIT" error is shown on the display and signaled by LEDs on CU board.
Actuator 2 (seat rotation)	0,4...1,4 <u>0,6</u>	A	Sets overcurrent threshold for seat rotation.
PW/M speed settings:			
Full speed UP	50...100 <u>100</u>	% PWM	Sets maximum speed for drive up
Full speed DOWN	50...100 <u>80</u>	% PWM	Sets maximum speed for drive down

Menu item		Value	Name	Description
	Slowdown UP	10...60 <u>50</u>	% PWM	Sets speed for drive up into station
	Slowdown DOWN	10...60 <u>25</u>	% PWM	Sets speed for drive down into station
	Curve UP	10...80 <u>75</u>	% PWM	Sets speed for drive up in curves
	Curve DOWN	10...80 <u>75</u>	% PWM	Sets speed for drive down in curves
	Rotation speed	10...100	% PWM	Sets speed for rotation of the seat.

Seat rotation (only available when swivel seat was ordered)

Menu item	Value	Name	Description
Automat/manual	<u>MANUAL</u>	<u>Standard</u>	This parameter sets up manual or electric rotation of the seat.
	AUTOMAT	Electric rotation of the seat	
IN UPPER STAT.	<u>YES</u>	<u>The seat is rotated in the upper station</u>	This parameter sets up if the seat is rotated in the upper station or if the rotation is blocked.
	NO	Seat's rotation blocked	
IN MIDDLE STOP	YES	Seat is rotated in the middle station	This parameter sets up if the seat is rotated in the middle station or if the rotation is blocked.
	<u>NO</u>	<u>Seat's rotation is blocked</u>	
IN LOWER STAT.	YES	The seat is rotated in the lower station	This parameter sets up if the seat is rotated in the lower station or if the rotation is blocked.
	<u>NO</u>	<u>Seat's rotation is blocked</u>	

Operation of footrest

Menu item	Value	Name	Description
Automat/manual	<u>MANUAL</u>	<u>Hand-operated/manual movement of the footrest</u>	This parameter sets up manual or electric movement (open/close) of the footrest.
	AUTOMAT	Electric movement of the footrest	
Moving time	1 – 10sec <u>2.5 sec</u>	Time of movement up/down of footrest	This parameter sets up time of electric movement (open or close) of the seat.

Options

Menu item	Value	Name	Description
Drive radio	Arm rest up/cl.	<u>Movement with opened (up) and closed armrest</u>	Command for movement from RF controllers according to the position of the armrest
	Arm rest up only	Movement with opened (up) armrest	

Error and operation diagnostic on the display

Error ID	Shown on display	Description
F101-113	Errors in relay and contacts	Main board failure – replace board

Following errors are recorded in EEPROM but they don't block operation of chair stairlift.

Error ID	Shown display text	Description
F201	EMERGENCY STOP SI: S7X	Emergency STOP-button
F202	Input S16 (and also S14 and S15) shorten	NOT IN USE
F203	OSG OVERSPEED SI: S10	Overspeed gear reacted during drive down, drive is now blocked mechanically
F204	Input S22U shorten	NOT IN USE
F205	DOWN/UP SAF.LIMIT SW SI: S22O	Down/up ultimate limit switch S22O is active – 1 switch for both directions → drive unit out of landing station with handwheel
F206	EMERG DRIVE SW SI: S8	Blocking during the emergency manual drive -> Remove handwheel
F301	SENSITIVE BOTTOM SI: S17	Sensitive bottom has been pushed while the stairlift was moving down
F302	DOWN SENS. PAD SI: S12/13,EKL/R	Sensitive pads and edges hit an obstacle in the direction down
F303	UP SENS. PAD SI: S12/13,EKL/R	Sensitive pads and edges hit an obstacle in the direction up
F401	OVERLOAD LIFT SI: SU	Overload of the chair stairlift – SU=1 switch is closed – currently not installed
F402	CURRENT LIMIT DRIVE MOTOR	Overcurrent detected on main drive M
F403	CURRENT LIMIT ACT1 – FOOTREST	overload/overcurrent detected on actuator 1 - footrest
F404	CURRENT LIMIT ACT2 - SEAT	Overload/overcurrent detected on actuator 2 – seat rotation
F405	EMPTY BATTERY STOP UP	Battery voltage dropped below 19.4 V, further up direction movement is blocked

Option: Automatic Swivel Seat

Following pictures can explain how to assemble the chairlift carriage and the upper automatic swivel seat. Main differences to manual version:

Height of the seat: 514 mm (it is 9mm higher than manual swivel)

Rotation range: from 0° to 80° (for rail inclination range 0° - 40°)

from 0° to 67° (for rail inclination range 40° - 52°)

All other parameters are the same.

The automatic swivel can be turned on / turn off for each automatic stop position separately.

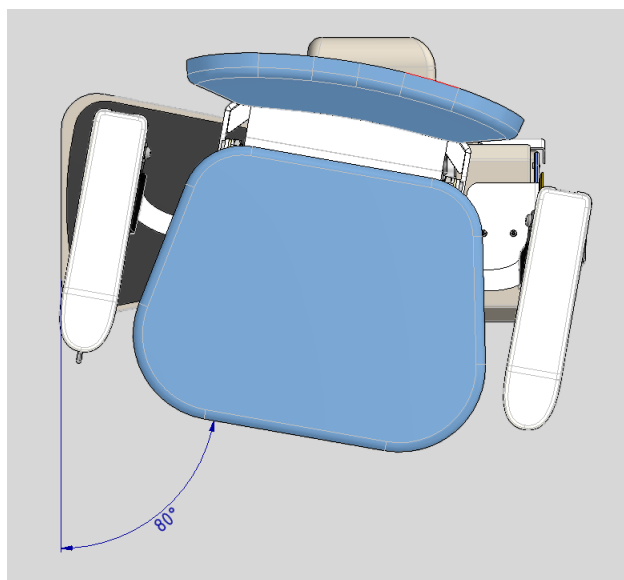
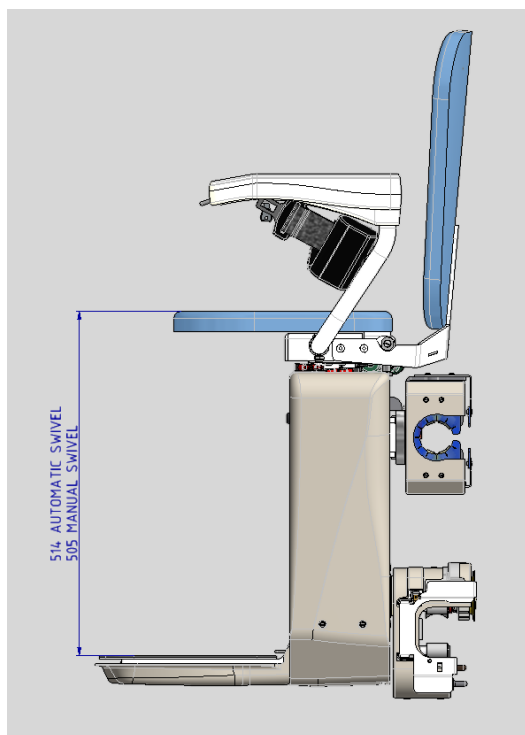

During final assembly on site it is necessary to be careful when connecting the lower and upper parts of the chairlift. The chairlift is delivered in two separate main parts like. The first step is to hang the carriage on the rail. During second step the upper part is connected.

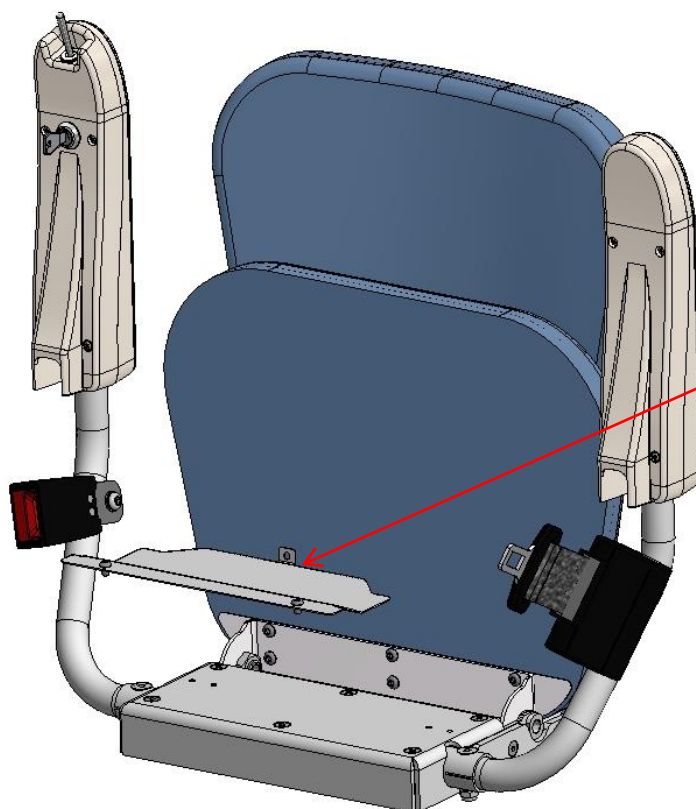
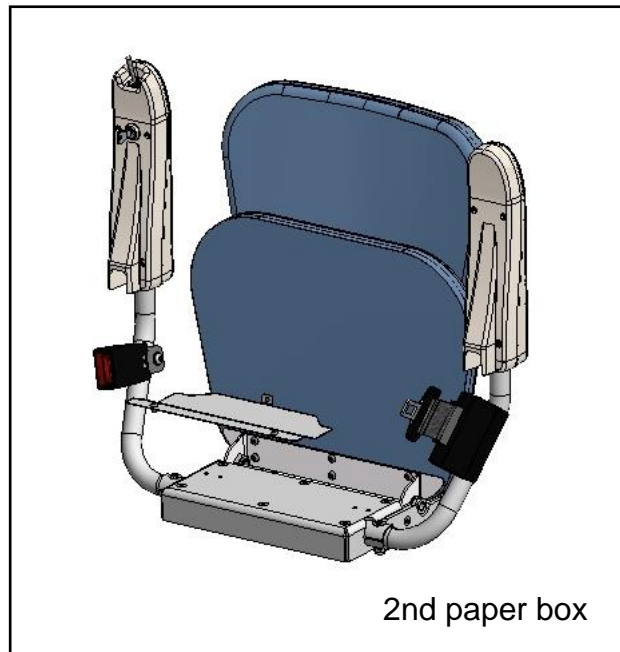
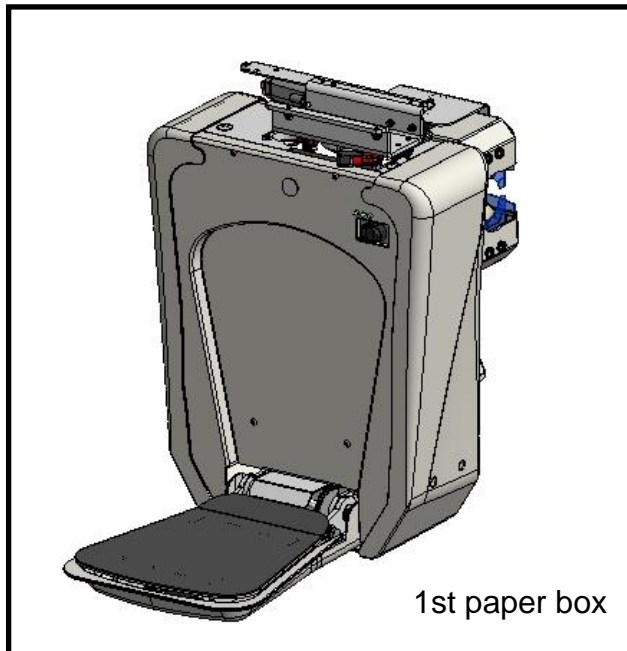

Remove cover with
3 pcs of the
screws for better
access to drive
unit and
trapezoidal screw

The upper part of the chairlift uses a different console for backrest and some different parts for rotation which are located at the dividing/connection plane.

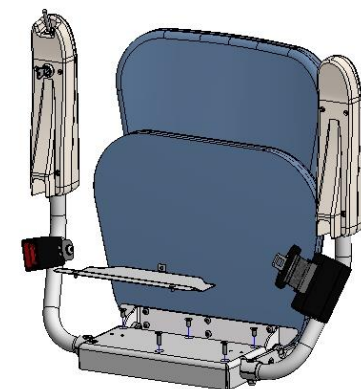
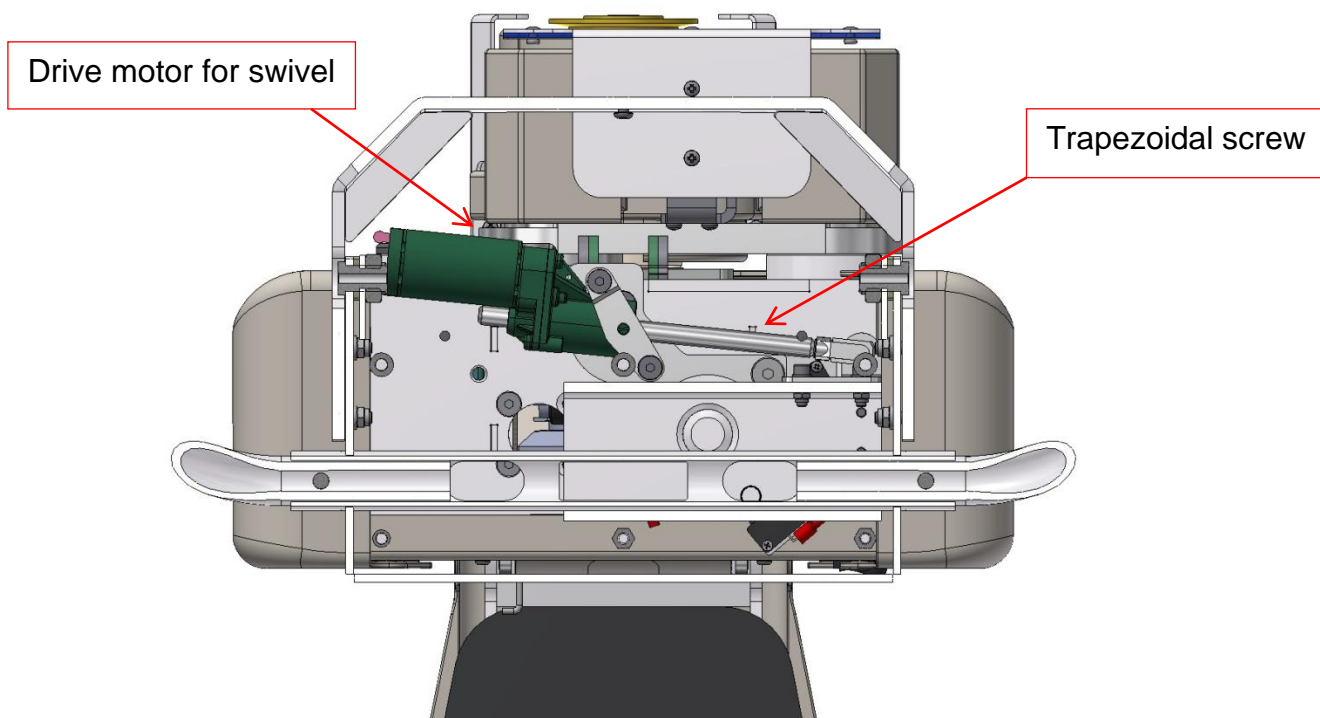

Upper part of the chair is mounted onto „U“ console of the drive unit with screws M6.

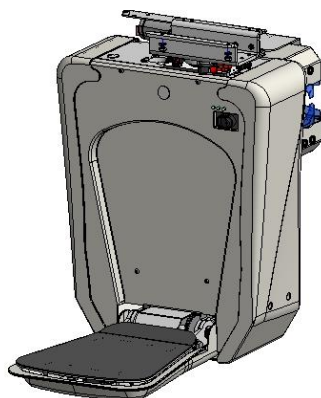

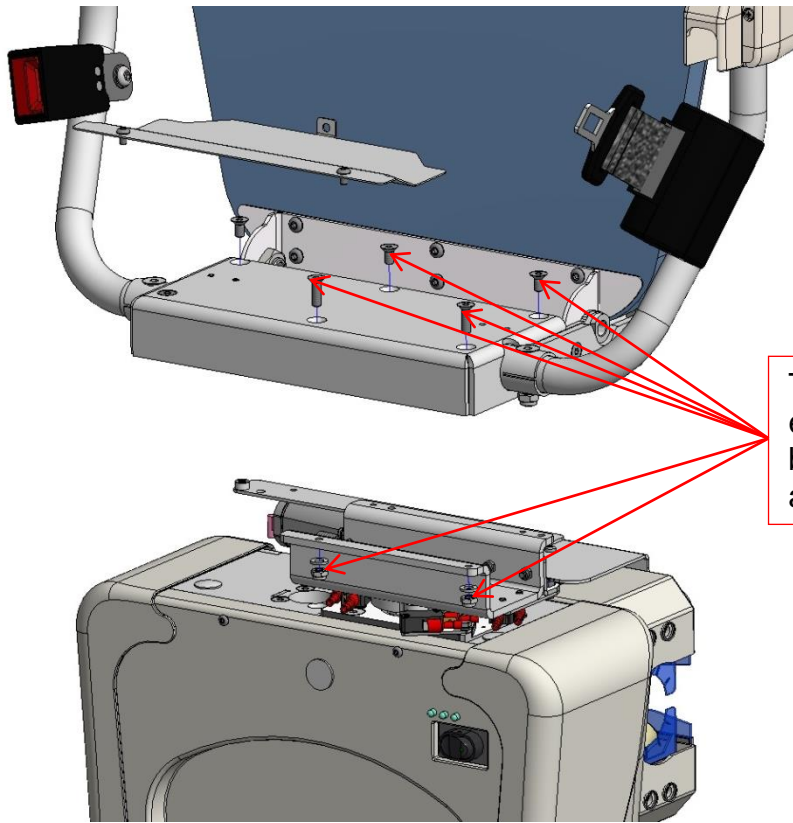

Two screws on front side are ensured with nuts from the bottom. Two screws on rear side are without nuts.

Remove the pin from the fork

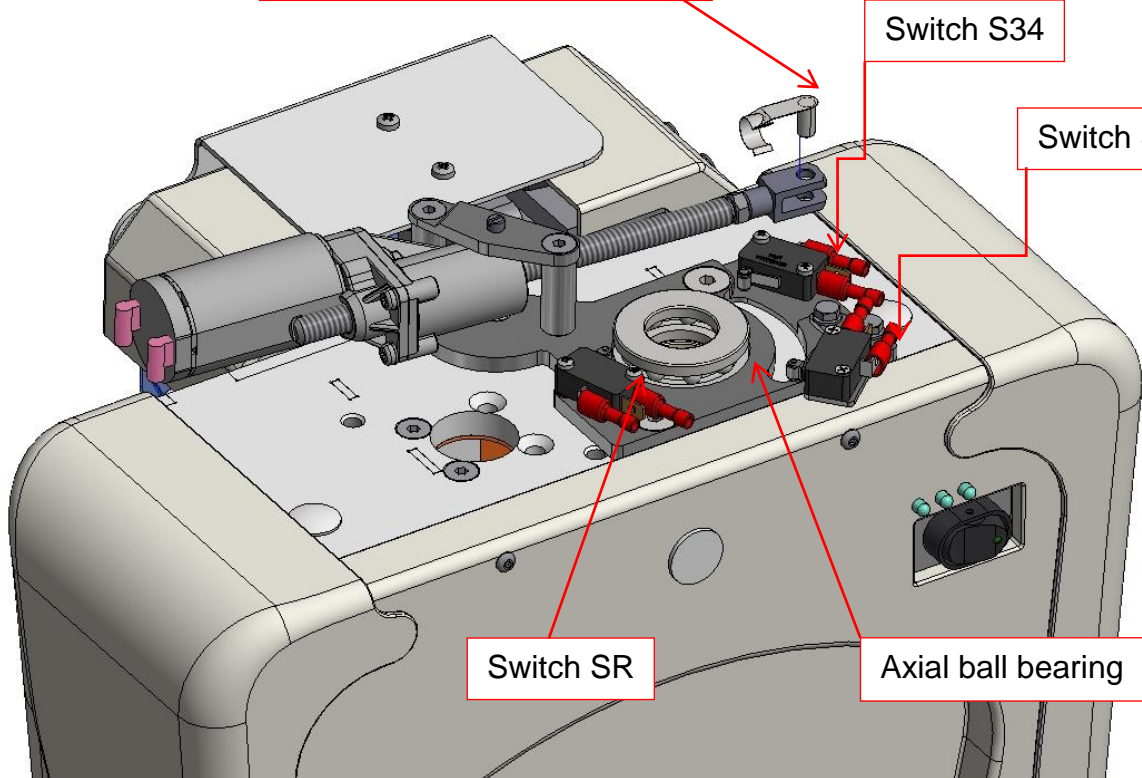

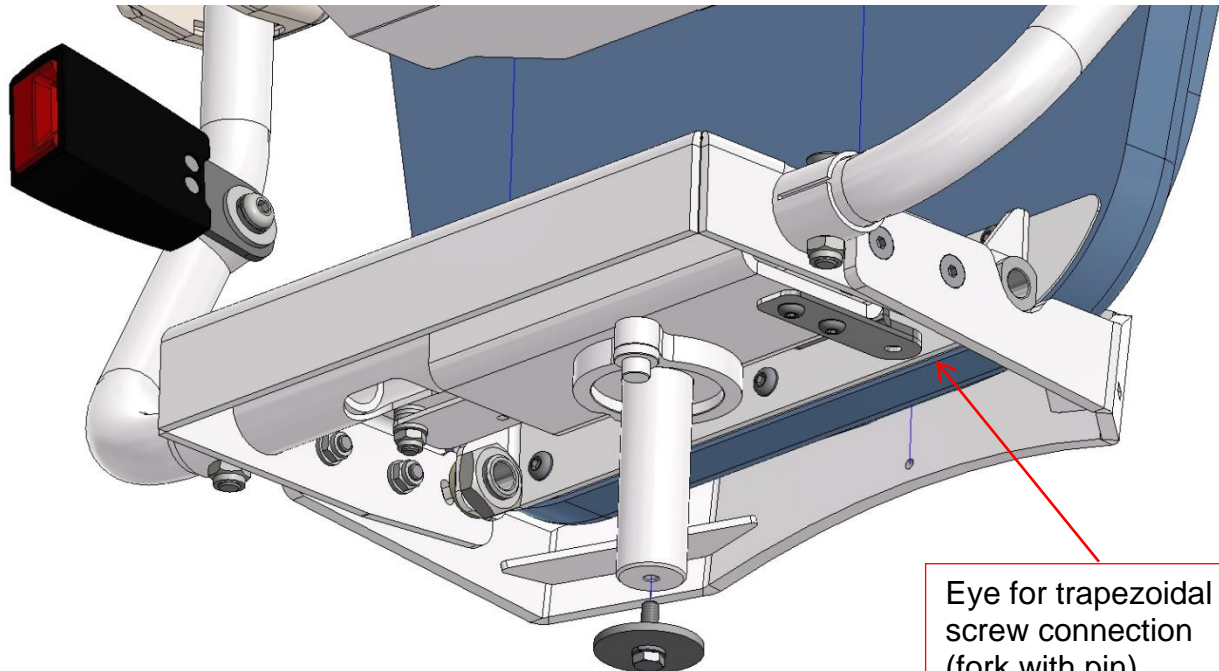

Eye for trapezoidal screw connection (fork with pin)

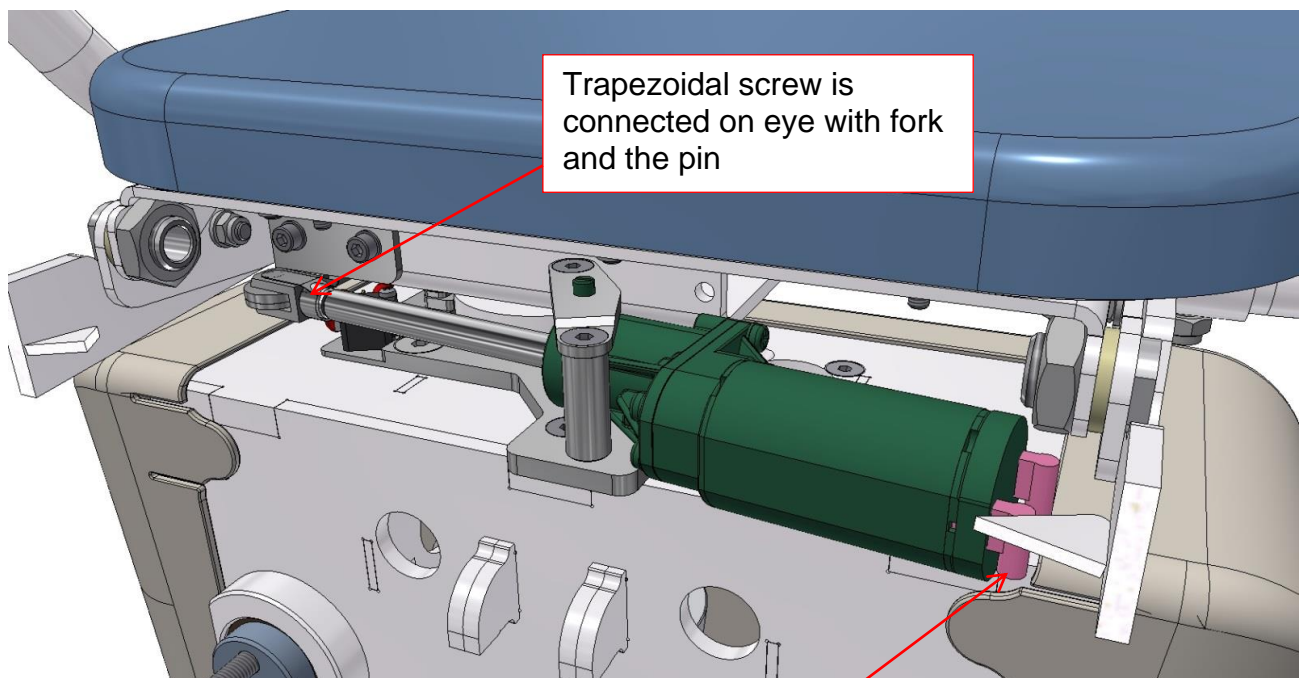

Trapezoidal screw is connected on eye with fork and the pin

Power supply for motor is connected on motor terminals

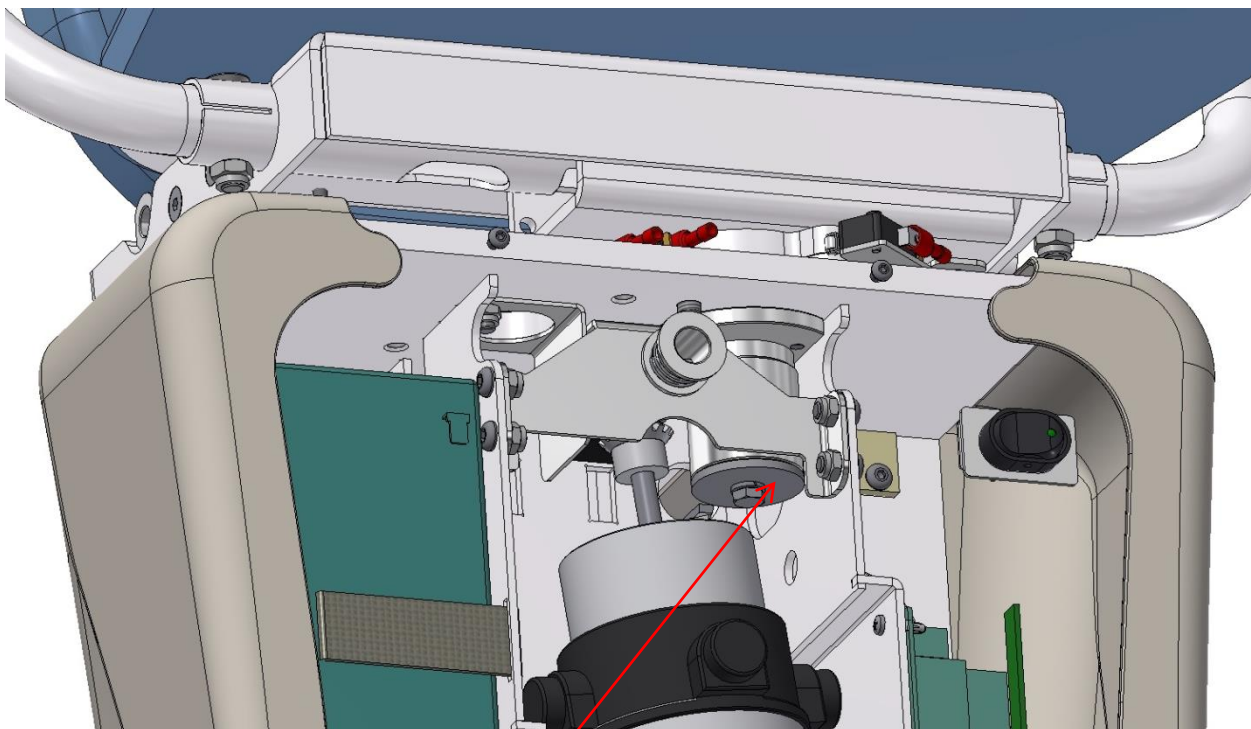

The big washer, spring washer and screw M6x20, DIN 933 are inserted in production factory. It protect the seat for upward movement and disconnection. It is important for good function of the automatic swivel.

When the automatic swivel is used then the landing control with 4 push buttons must be used.

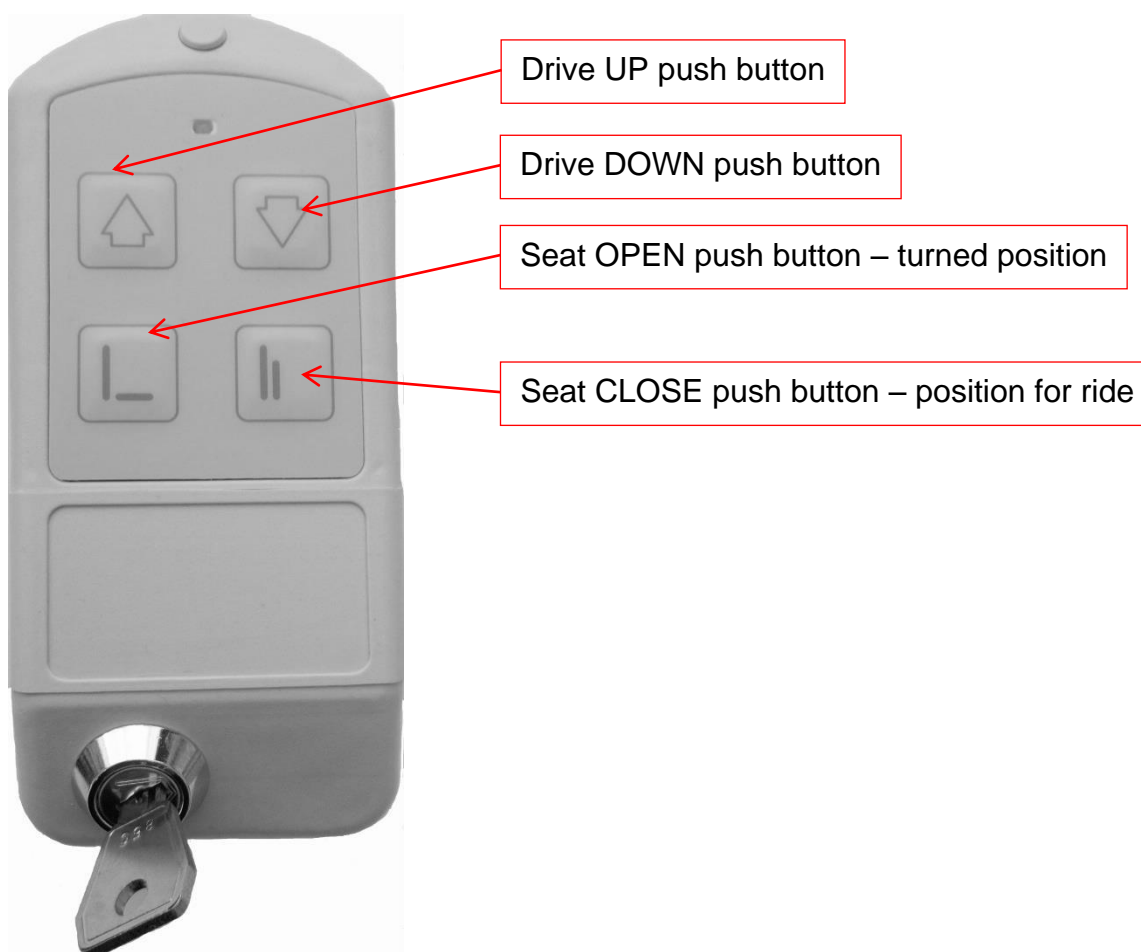

Position of the switch S34 must be chosen in accordance with rail inclination. Each swivel seat stop position must be checked and adjusted after installation in accordance with the user requests.

- 1) For rail inclination in range $0^\circ - 40^\circ$ full range of rotation can be used. Switch S34 is mounted in accordance with the following picture.

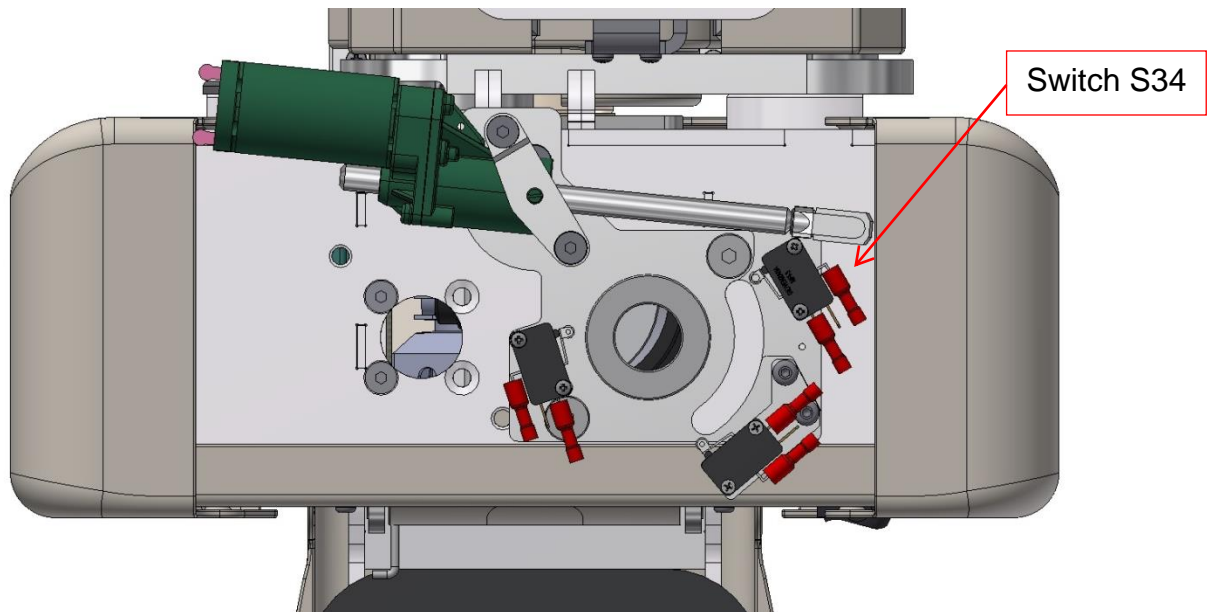

- 2) For rail inclination in range $40^\circ - 52^\circ$ only a reduced range of rotation (up to 67°) can be used. Switch S34 is mounted in accordance with the following picture.

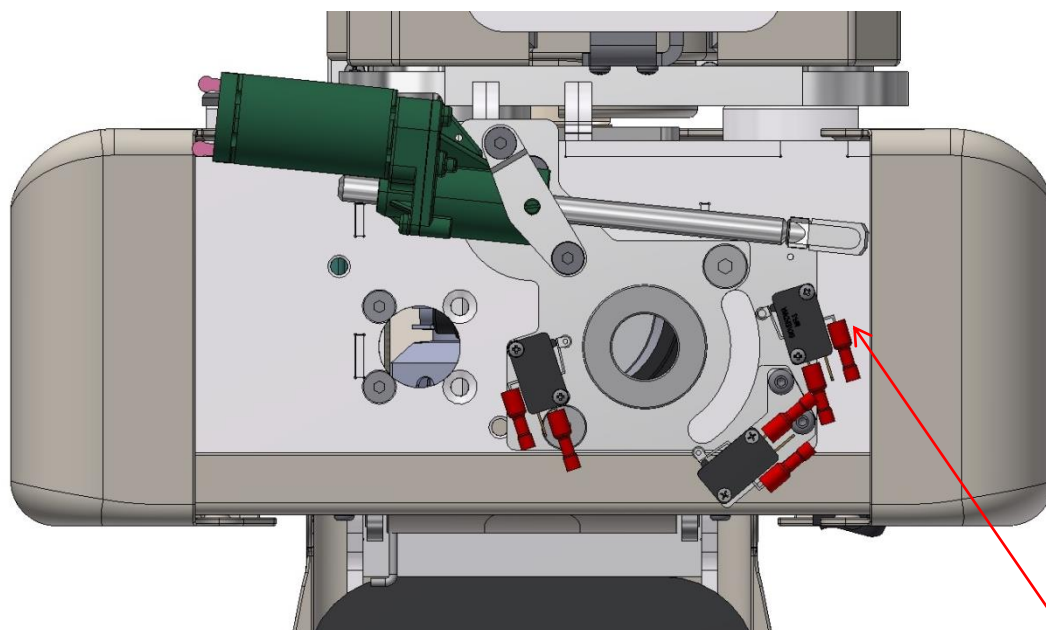

Switch S34 is a little bit further from the end of circle groove

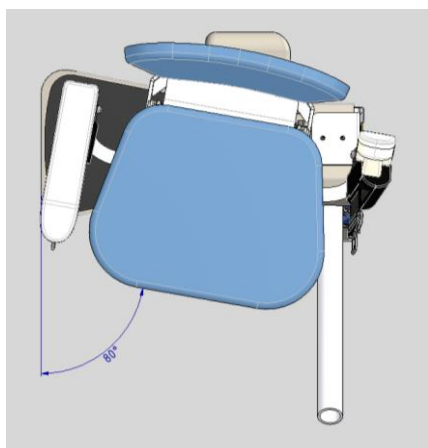

Full rotation range

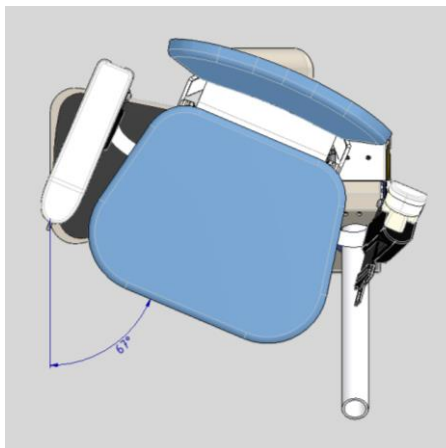

Reduced rotation range

The main reason why the rotation must be reduced when the rail is steep is to receive a safety gap between seat and upper rail tube for hand or fingers.

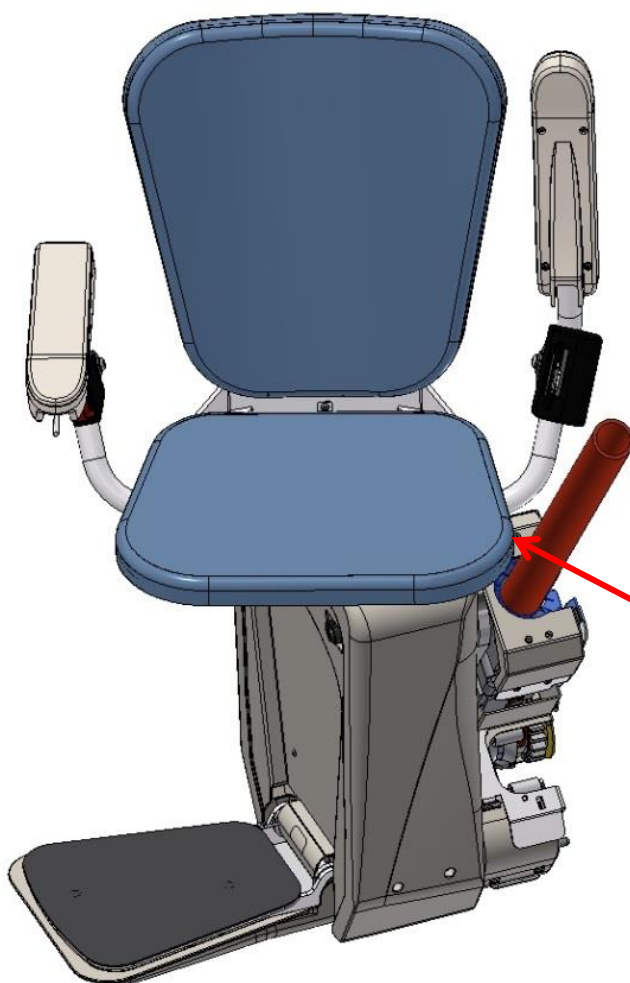

The seat cannot rotate more because of clashing with the rail tube

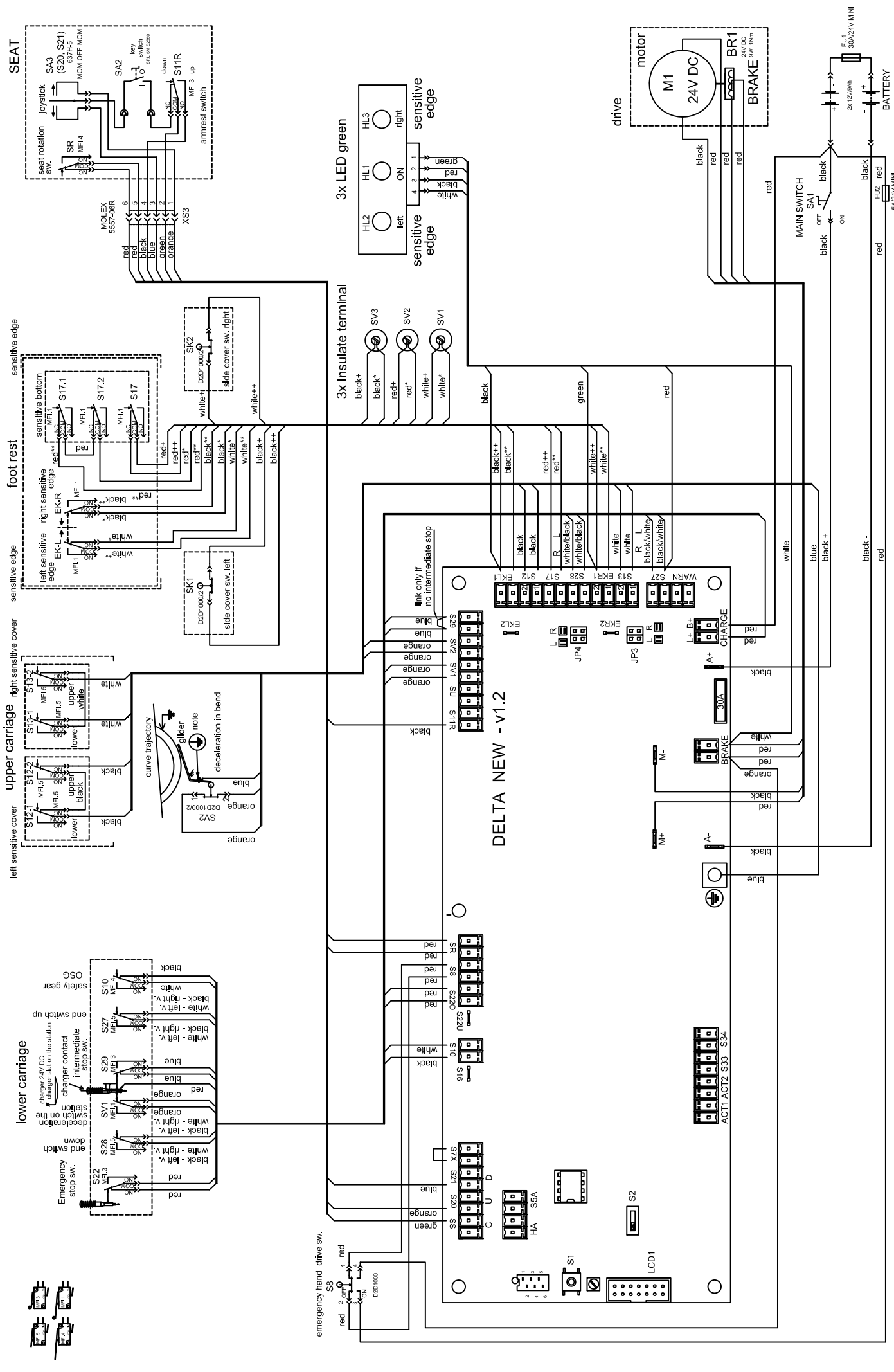

ALPHA MANUAL

