

KITZ

F SERIES

Pneumatic Actuators for Ball and Butterfly Valves

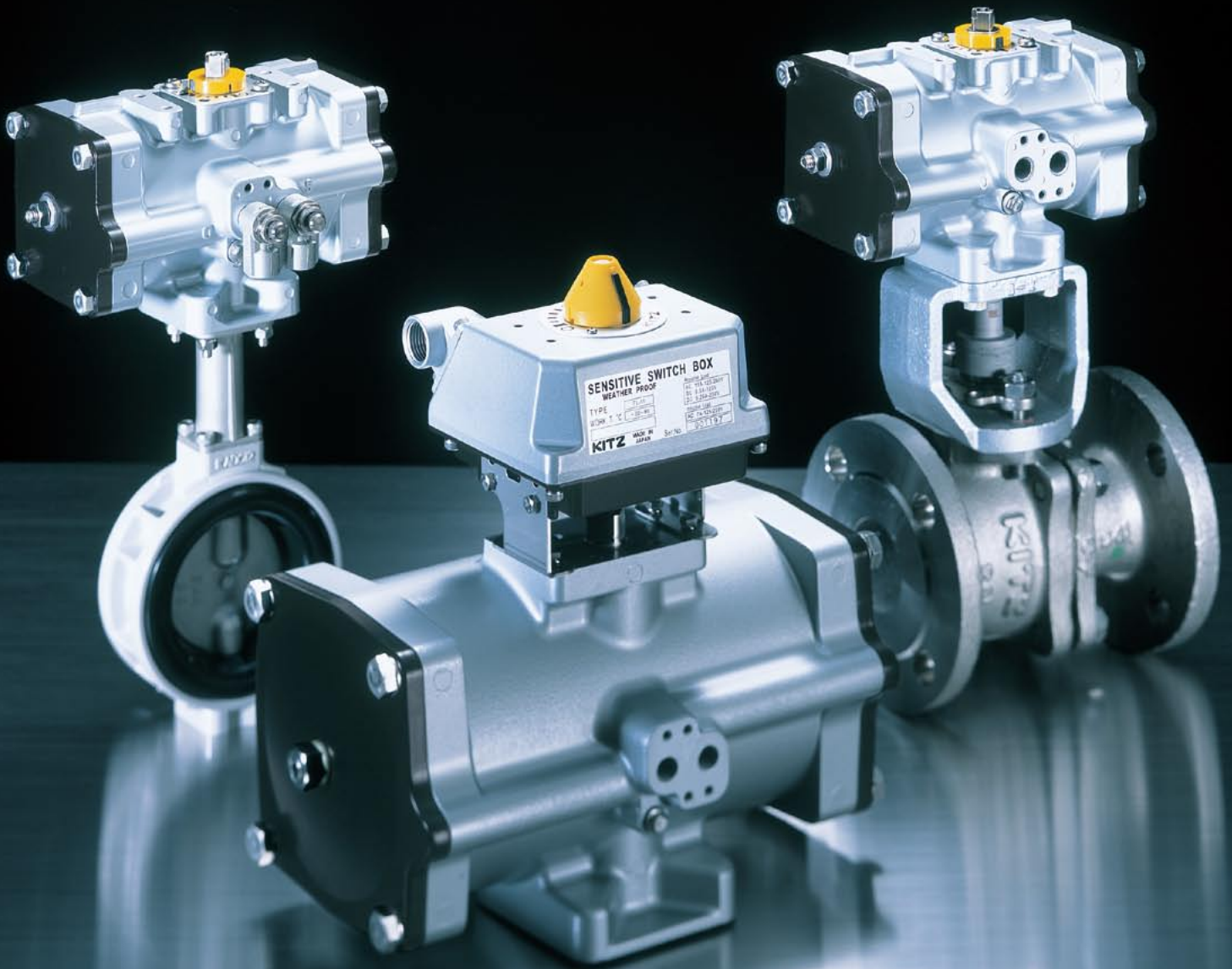

KITZ CORPORATION

KITZ F SERIES

Pneumatic Valve Actuators



Featured by the utmost handling ease and extended service life with high operational efficiency

Easy answers to engineering modification requirements

- Position indicator can be adjusted by 90°, when actuator mounting position is turned by 90°, for local piping or operating convenience.
- Actuator shaft rotating angle (valve opening/closing range) can be adjusted with optional longer stopper bolt to full 90° rotation from standard range of plus/minus 7°.

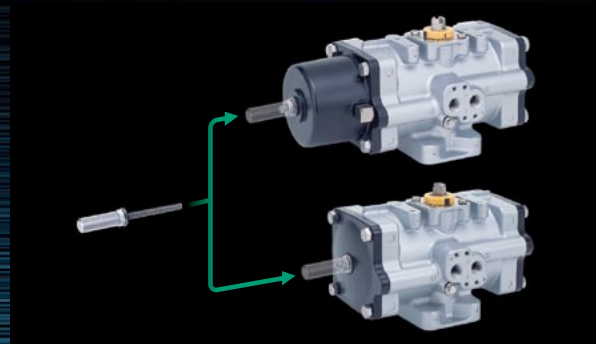
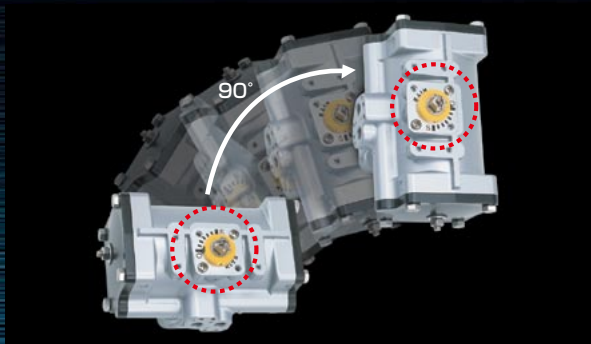

- Standard AIR-FAIL-CLOSE mode can be converted to AIR-FAIL-OPEN mode by means of mounting of spring cartridge on the actuator housing reverse end. (spring-return type only)
- Replacing modular units of blowoff-proof spring cartridge enables accommodation of higher output torque or lower operating pressure. (spring-return type only)

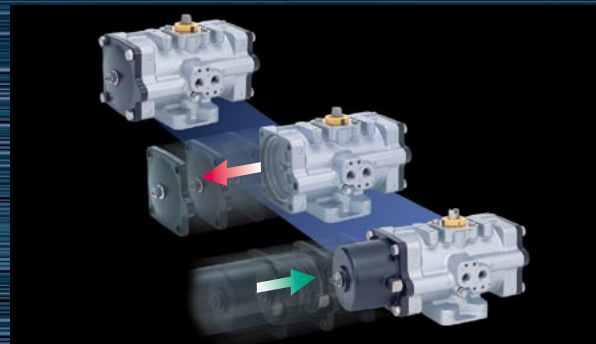
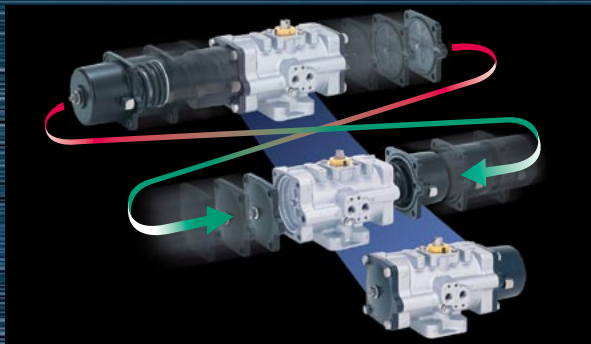

- Valve actuation mode is convertible between double-action and spring-return with addition or deletion of spring cartridge.

Economic advantage

Use of monobloc casting of piston-rack assembly results in reduced housing dimensions by 10% to 15% (compared with KITZ D Series actuators), and saves air consumption for valve actuation.

Extended service life with monobloc casting of two pistons and a gear-rack

Threads of a gear-rack is positioned in the center of actuator housing, and two pistons are cast in integration with gear-rack as one-piece unit. This helps to keep piston position in parallel during actuator travel.

Light and compact housing

Employment of diecast aluminum for housings and piston-rack assemblies has reduced the actuator weight by 20% to 40% (compared with KITZ D Series actuators) for better torque-to-weight ratio.

Conformity to international standards

NAMUR VDI/VDE 3845 designs are used for tubeless mounting of solenoid valve and switchbox on actuator housing besides the conformity to ISO 5211 requirements for valve mounting flanges. The stem top design also conforms to NAMUR dimensions.

Actuators can be directly mounted to KITZ DJ, XJ Series Butterfly Valves

Optional adaptors (connectors) to the valves on the bottom of actuators can be provided for wide mounting variations

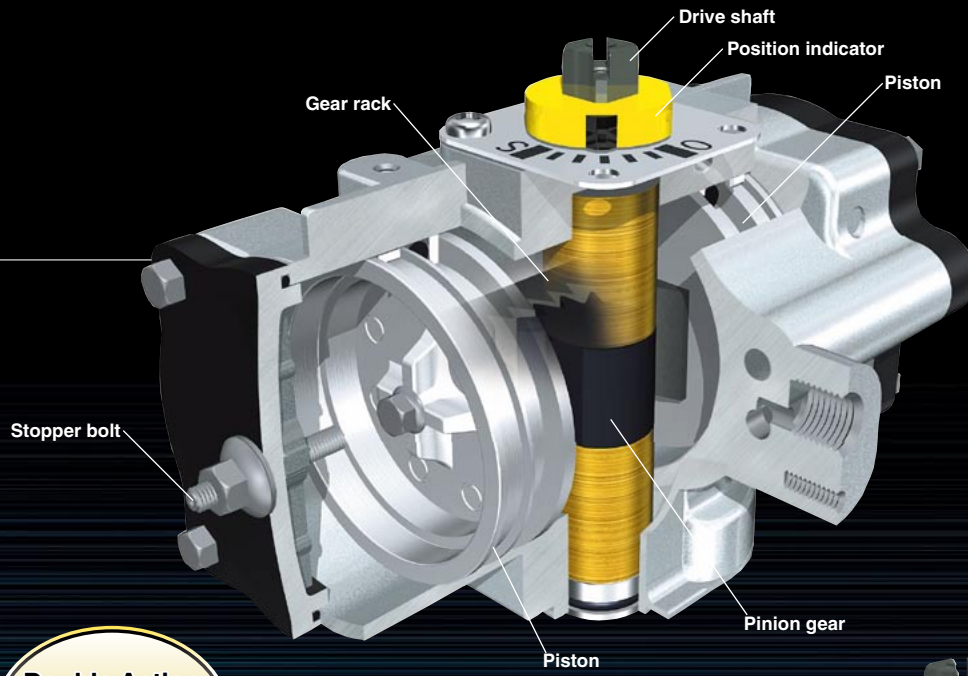

**Double Action
Type
FA**

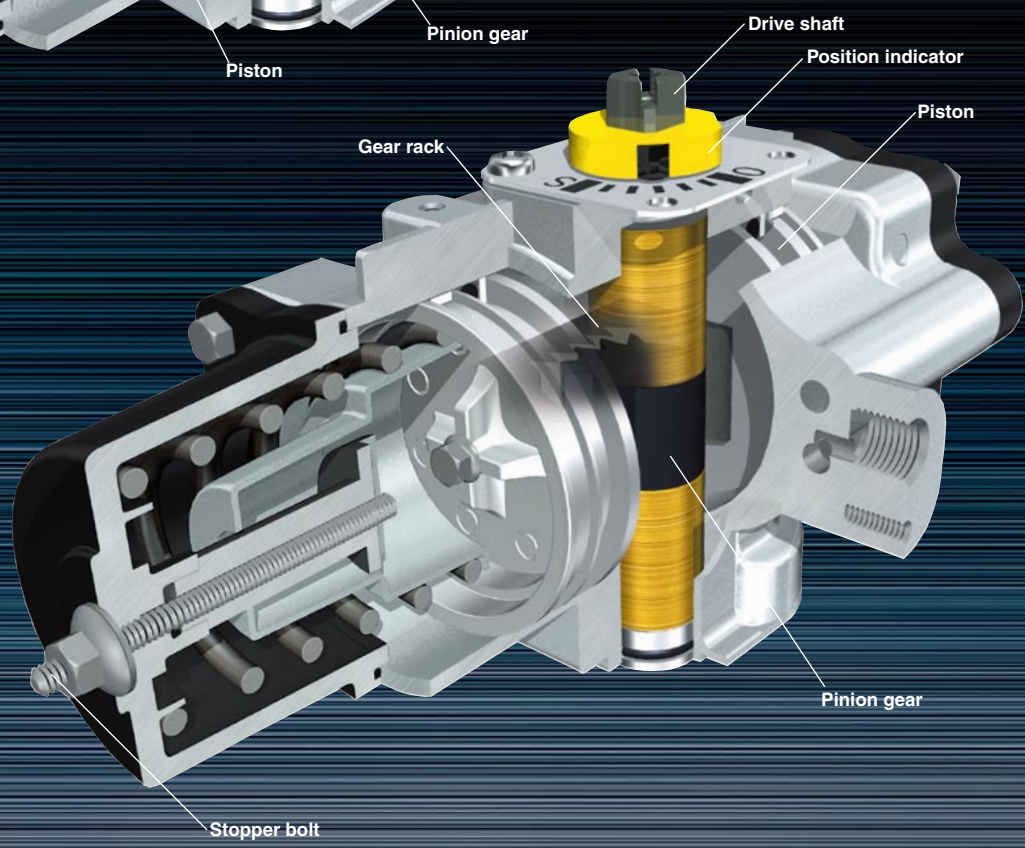

**Spring Return
Type
FAS**

Specifications

Operating medium	Compressed instrumentation air or nitrogen gas
Operating pressure	Standard operating pressure 0.39 MPa
Operating pressure range	0.29 MPa to 0.69 MPa*
Cylinder test pressure	0.97 MPa
Shaft rotating angle	90°±7°
Service temperature	-20°C to +80°C (Supply air should not be frozen.)
Opening degree indication	Indicator has 15 degree graduation
Valve mounting flange	ISO 5211
Accessory mounting connection	NAMUR VDI/VDE 3845
Coating	Baked Polyester Resin Coating

* Be consulted by KITZ for non-standard operating pressure.

Product Coding

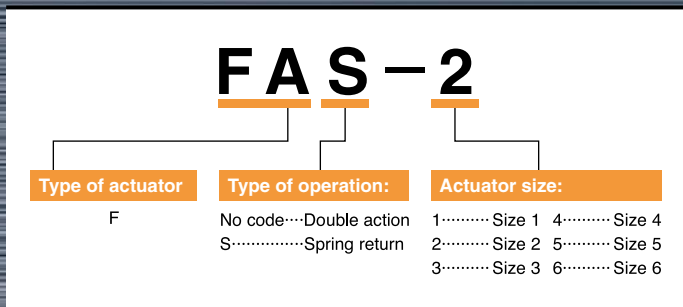

● Operating Mechanism

■ Double action (Type FA)

- (1) Air pressure supplied into the chamber **A** through port ①, pushes gear rack with two pistons outward, and discharges the air residue through port ②.
- (2) The gear rack rotates the pinion gear and the shaft counter-clockwise, to drive the valve.
- (3) Reverse supply of the air pressure activates reverse valve operation.

Cylinder volume

unit: ℓ

Type	Chamber A	Chamber B
FA-1	0.15	0.15
FA-2	0.31	0.31
FA-3	0.61	0.61
FA-4	1.29	1.29
FA-5	2.29	2.29
FA-6	5.27	5.27

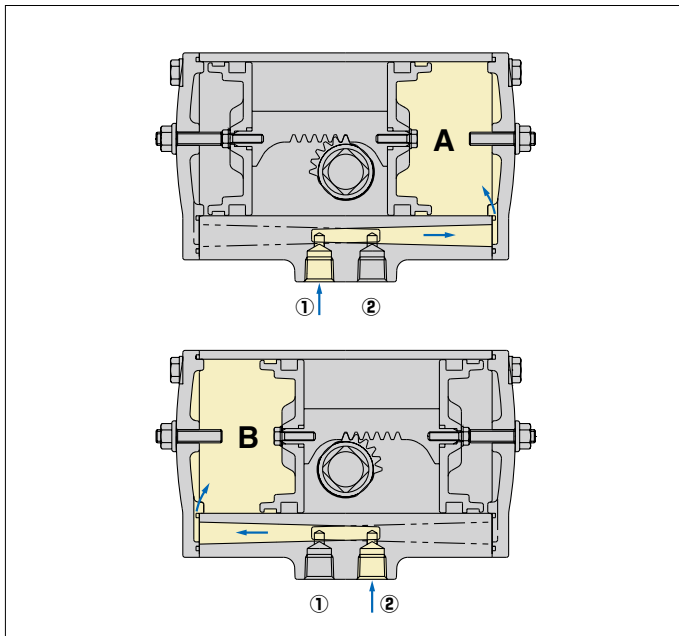

■ Spring return (Type FAS)

- (1) Air pressure supplied into the chamber **A** through port ①, pushes gear rack with two pistons outward, compresses the springs and discharges the air residue through port ②.
- (2) The gear rack rotates the pinion gear and the shaft counter-clockwise, to drive the valve.
- (3) At the moment the air in the chamber **A** is discharged through the solenoid valve, the spring force pushes the pistons to the reverse direction, and the gear rack activates rotation of the shaft clockwise to reversely operate the valve.

Cylinder volume

unit: ℓ

Type	Chamber A
FAS-1	0.15
FAS-2	0.31
FAS-3	0.61
FAS-4	1.29
FAS-5	2.29
FAS-6	5.27

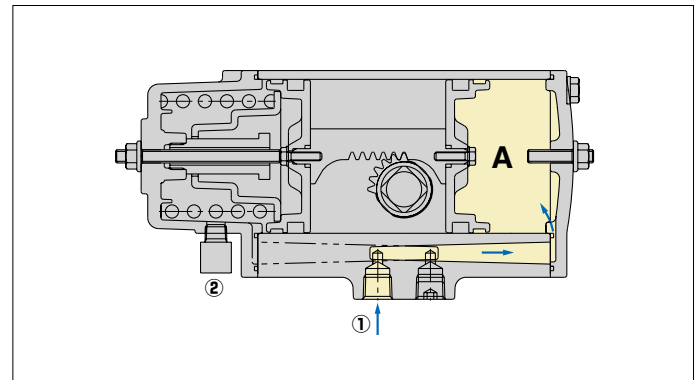

● Actuator Output Torque

■ Double action

unit: N·m

Type	Operating pressure (air)		
	0.29MPa	0.39MPa	0.49MPa
FA-1	14.12	18.83	23.54
FA-2	33.41	44.54	55.68
FA-3	67.37	89.83	112.30
FA-4	134	179	223
FA-5	244	332	407
FA-6	588	784	980

■ Double action

unit: LB·IN.

Type	Operating pressure (air)		
	45psi	60psi	75psi
FA-1	125	166	208
FA-2	296	394	493
FA-3	597	795	991
FA-4	1186	1584	1974
FA-5	2160	2939	3602
FA-6	5204	6939	8674

■ Spring return

unit: N·m

Type	Spring rating	Operating pressure (air)						Operating force (spring)	
		0.29MPa		0.39MPa		0.49MPa		0°※3	90°※4
		0°※1	90°※2	0°※1	90°※2	0°※1	90°※2		
FAS-1	3K	9.25	6.51	14.06	11.32	18.87	16.12	5.18	7.92
	4K	—	—	11.66	7.64	16.47	12.45	7.58	11.60
	5K	—	—	—	—	14.60	9.60	9.44	14.45
FAS-2	3K	20.19	13.68	31.32	24.81	42.45	35.95	13.21	19.71
	4K	—	—	26.76	18.02	37.89	29.15	17.76	26.50
	5K	—	—	—	—	33.39	22.43	22.26	33.22
FAS-3	3K	42.83	32.72	64.00	52.89	87.16	75.06	23.68	35.79
	4K	—	—	53.52	35.54	75.69	57.71	35.16	53.14
	5K	—	—	—	—	66.79	44.41	44.06	66.43
FAS-4	3K	83.00	59.40	129	106	175	152	55.60	79.10
	4K	—	—	110	74.60	157	121	74.30	110
	5K	—	—	—	—	138	93.20	93.10	138
FAS-5	3K	155	109	240	194	325	279	101	147
	4K	—	—	203	138	288	222	138	203
	5K	—	—	—	—	255	171	171	254
FAS-6	3K	354	249	551	446	748	643	237	342
	4K	—	—	473	326	670	510	326	475
	5K	—	—	—	—	591	392	394	593

■ Spring return

unit: LB·IN.

Type	Spring rating	Operating pressure (air)						Operating force (spring)	
		45psi		60psi		75psi		0°	90°
		0°	90°	0°	90°	0°	90°		
FAS-1	45psi	82	58	124	100	167	143	46	70
	60psi	—	—	103	68	146	110	67	103
	75psi	—	—	—	—	129	85	84	128
FAS-2	45psi	179	121	277	220	376	318	117	174
	60psi	—	—	237	159	335	258	157	235
	75psi	—	—	—	—	296	199	197	294
FAS-3	45psi	379	290	566	468	771	664	210	228
	60psi	—	—	474	315	670	511	311	470
	75psi	—	—	—	—	591	393	390	588
FAS-4	45psi	735	526	1142	938	1549	1549	492	700
	60psi	—	—	974	660	1390	1390	658	974
	75psi	—	—	—	—	1221	1221	824	1221
FAS-5	45psi	1372	965	2124	1717	2877	2877	894	1301
	60psi	—	—	1797	1221	2549	2549	1221	1797
	75psi	—	—	—	—	2257	2257	1514	2248
FAS-6	45psi	3133	2204	4877	3948	6621	6621	2098	3027
	60psi	—	—	4187	2770	5930	4514	2788	4204
	75psi	—	—	—	—	5231	3470	3487	5249

※1 At starting point (close position) ※2 At ending point (open position) ※3 At ending point (close position) ※4 At starting point (open position)

● Dimensions

Double action (Type FA)

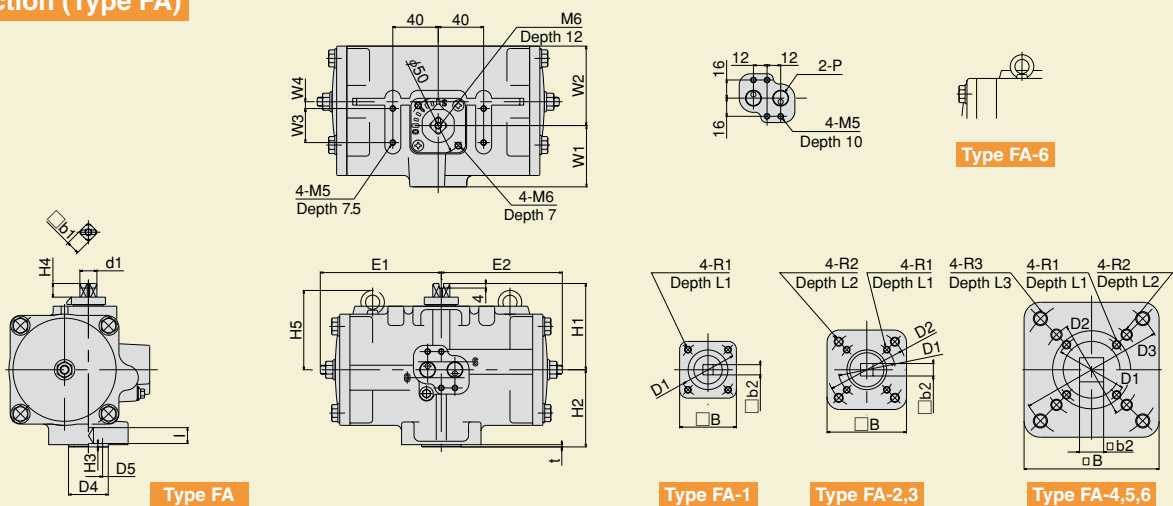

unit:mm

Type	E1	E2	W1	W2	W3	W4	H1	H2	H3	H4	H5	D1	D2	D3	D4	D5	d1	b1	b2	B	ℓ	t	R1×L1	R2×L2	R3×L3	P	Weight (kg)
FA-1	87	87	50	54	30	0	70	55	3	12	—	50	—	—	35	25	15	12	9	50	16	2	M6×9	—	—	Rc¼	1.7
FA-2	107	107	54	70	30	6	80	68	3	12	—	50	70	—	35	30	15	12	11	70	16	2	M6×9	M8×12	—	Rc¼	2.9
FA-3	128	128	57	87	30	13	86	78	3	12	—	50	70	—	35	32	21	17	13	70	25	2	M6×9	M8×12	—	Rc¼	4.4
FA-4	160	160	68	111	30	21	108	96	4	12	—	50	70	102	55	40	21	17	17	95	27	3	M6×9	M8×12	M10×15	Rc¼	8.0
FA-5	208	208	78	135	30	30	132	116	5	20	—	70	102	125	55	50	29	23	27	113	34	3	M8×12	M10×15	M12×18	Rc¼	13.6
FA-6	268	268	101	178	30	45	152	125	5	20	160	70	102	125	70	60	41	32	27	134	34	3	M8×12	M10×15	M12×18	Rc¼	28.2

Spring return (Type FAS)

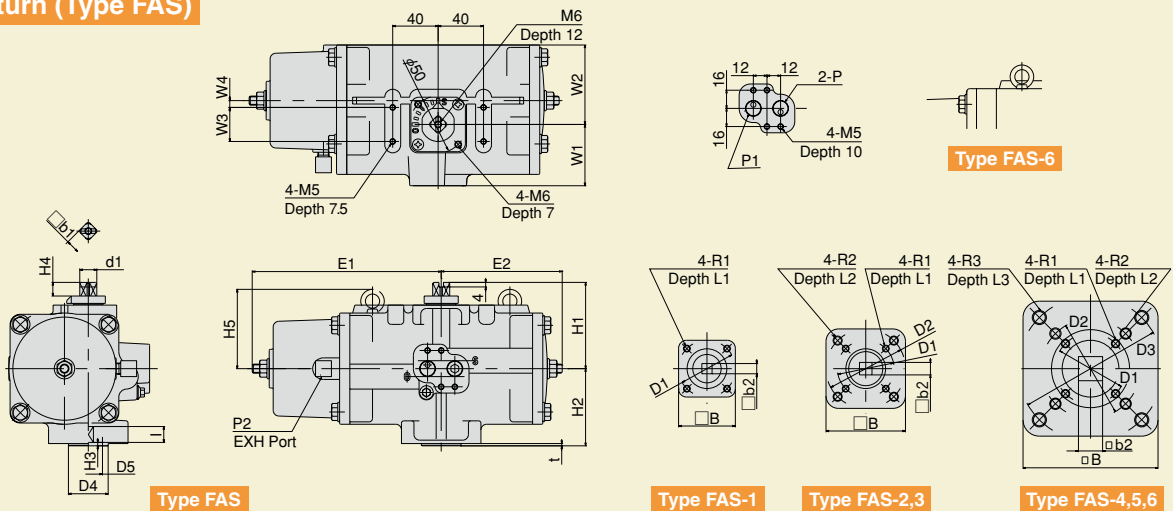

unit:mm

Type	E1	E2	W1	W2	W3	W4	H1	H2	H3	H4	H5	D1	D2	D3	D4	D5	d1	b1	b2	B	ℓ	t	R1×L1	R2×L2	R3×L3	P1	P2	Weight (kg)
FAS-1	132	87	50	54	30	0	70	55	3	12	—	50	—	—	35	25	15	12	9	50	16	2	M6×9	—	—	Rc¼	Rc⅜	2.1
FAS-2	166	107	54	70	30	6	80	68	3	12	—	50	70	—	35	30	15	12	11	70	16	2	M6×9	M8×12	—	Rc¼	Rc⅜	3.8
FAS-3	203	128	57	87	30	13	86	78	3	12	—	50	70	—	35	32	21	17	13	70	25	2	M6×9	M8×12	—	Rc¼	Rc⅜	6.4
FAS-4	290	160	68	111	30	21	108	96	4	12	—	50	70	102	55	40	21	17	17	95	27	3	M6×9	M8×12	M10×15	Rc¼	Rc⅜	12.8
FAS-5	363	208	78	135	30	30	132	116	5	20	—	70	102	125	55	50	29	23	27	113	34	3	M8×12	M10×15	M12×18	Rc¼	Rc⅜	23.4
FAS-6	483	268	101	178	30	45	152	125	5	20	160	70	102	125	70	60	41	32	27	134	34	3	M8×12	M10×15	M12×18	Rc¼	Rc⅜	50.0

Optional Accessories

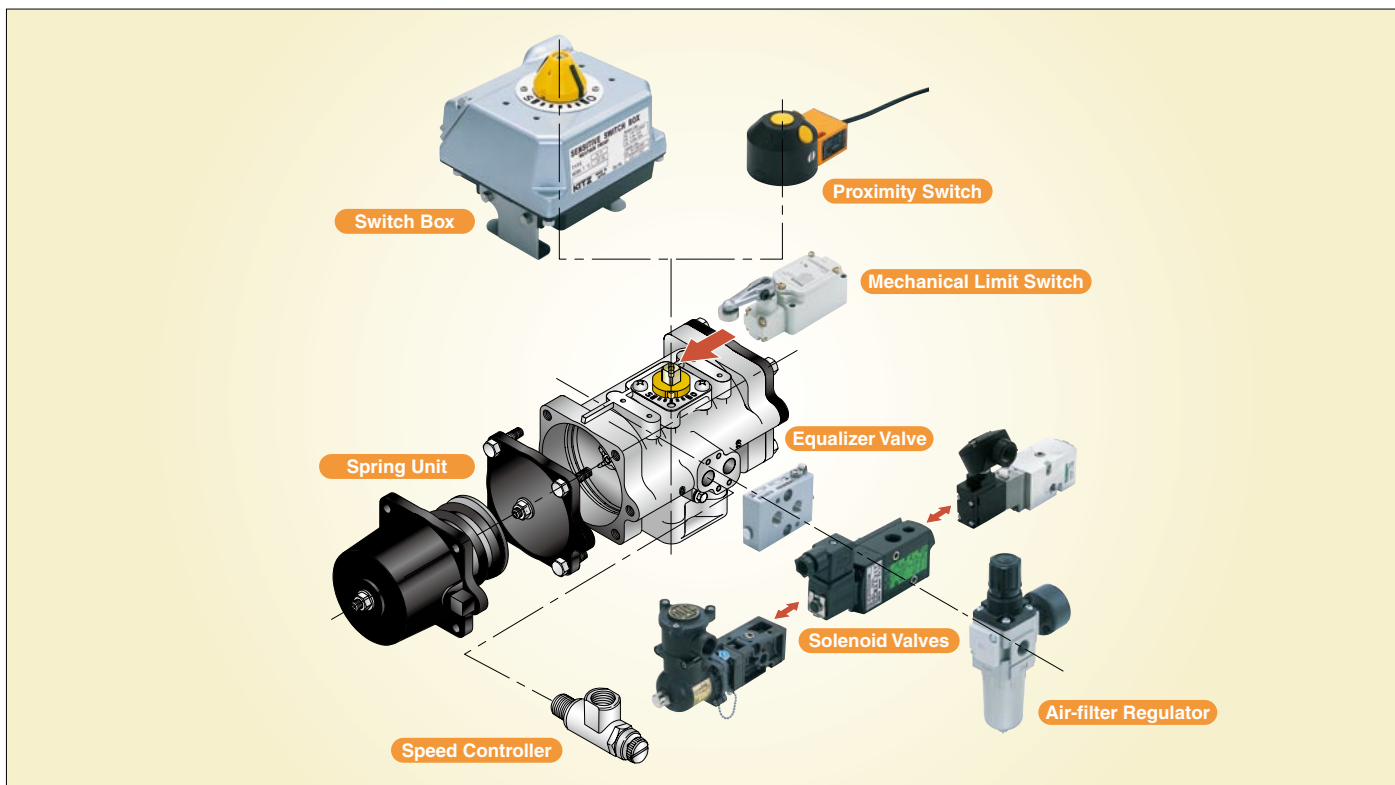

Construction Details

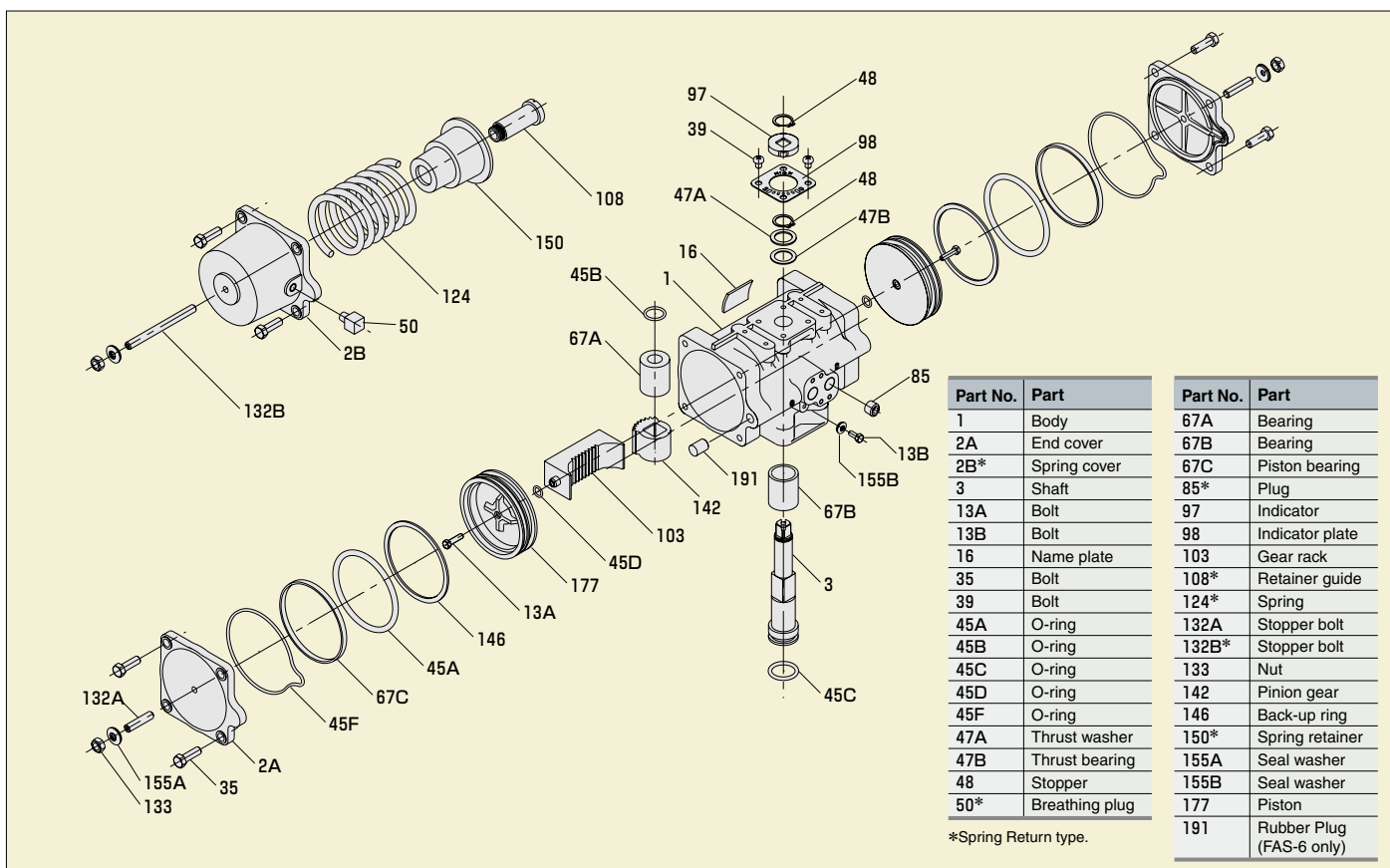

● Actuator Sizing

The sizing shown below is based on the following conditions.

■ Ball valves

Operating pressure	0.39 MPa
Fluid type	<ul style="list-style-type: none"> · Fresh water or lubricant, Max. 0.98 MPa (*The figures shown in the table indicate service pressure limit. Unit MPa) · Air gas or steam, Max. 0.69 MPa
Fluid temperature	-20°C to +230°C (Limited within seat rating)

Be consulted by KITZ, if:

- ① Valves handle
 - a. Solvents, such as kerosene, naphtha or alcohol.
 - b. Powder, slurry or dehydrated cake.
 - c. Vacuum or any other service requiring oil free treatment.
- ② Valves are not operated for more than 3 months.
- ③ Valves are used as a control valve.

■ Butterfly valves

Operating pressure	0.39 MPa
Fluid type	Smooth fluid ● Fresh water, lubricant (Max 1,000 cp)
Velocity	Up to 2m/sec
Fluid temperature	0°C to Max. working temperature

Type, temperature and pressure of the fluid shall be determined by the rubber seat. Valve selection must properly be made based on these conditions.

Extra care shall be taken on velocity, if valves are used at the pump exit.

■ Type FA Double action

Type	Bore	Shell Material	Class	Conection	Product coding	Size																		
						A	10	15	20	25	32	40	50	65	80	100	125	150	200	250	300			
						B	3/8	1/2	3/4	1	1 1/4	1 1/2	2	2 1/2	3	4	5	6	8	10	12			
Ball Valve	Full Port	Cast Iron	JIS 10K	Threaded	10FCT																			
				Flanged	10FCTB																			
		Ductile Iron	JIS 10K	Flanged	10STBF																			
					Threaded	10UT																		
		Stainless Steel	JIS 10K Class 150	Flanged	10/150UTB, 10/150UTDZ																			
					20/300UTB, 20/300UTDZ																			
			Carbon Steel	JIS 10K Class 150	Flanged	10/150SCTB, 10/150SCTDZ																		
						20/300SCTB, 20/300SCTDZ																		
		Reduced Port	Stainless Steel	JIS 10K Class 150	Flanged	10UTR, 150UTR																		
						20UTR, 300UTR																		
	Carbon Steel		Class 150	Flanged	150SCTR																			
					300SCTR																			
	Full Port (3way)	Stainless Steel	JIS 10K	Flanged	10UTB4T (L) A																			
	Full Port (PFA Lining)				10UTBLN																			
Butterfly Valve	Aluminum	JIS 10K	Wafer	10XJME																				
				10XJSME																				
	Ductile Iron	JIS 16K BS PN16	Wafer	10DJ																				
				16DJ, PN16DJ																				

● Actuator Sizing

■ Type FAS Spring Return

Type	Bore	Shell Material	Class	Conection	Product coding	Size		10	15	20	25	32	40	50	65	80	100	125	150	200	250	300			
						A	B	3/8	1/2	3/4	1	1 1/4	1 1/2	2	2 1/2	3	4	5	6	8	10	12			
Ball Valve	Full Port	Cast Iron	JIS 10K	Threaded	10FCT																				
				Flanged	10FCTB																				
		Ductile Iron		10STBF																					
				Threaded	10UT																				
		Stainless Steel	JIS 10K Class 150	Flanged	10/150UTB, 10/150UTDZ			FAS-1		FAS-2		FAS-3		FAS-4		FAS-5		FAS-6							
					20/300UTB, 20/300UTDZ																				
			Carbon Steel	JIS 10K Class 150	Flanged	10/150SCTB, 10/150SCTDZ																			
						20/300SCTB, 20/300SCTDZ																			
	Reduced Port	Stainless Steel	JIS 10K Class 150	Flanged	10UTR, 150UTR																				
					JIS 20K Class 300	20UTR, 300UTR																			
		Carbon Steel	Class 150		150SCTR																				
					Class 300	300SCTR																			
		Stainless Steel	JIS 10K		10UTB4T (L) A																				
					10UTBLN																				
Butterfly Valve	Aluminum	JIS 10K	Wafer	10XJME																					
				10XJSME																					
	Ductile Iron	JIS 16K BS PN16		10DJ																					
				16DJ, PN16DJ																					

● Precautions

CAUTION

- Ensure to read and follow instructions of operation manual when handling F Series actuators.
- Ensure to select F Series actuators in consideration of specifications of this catalog.
- Refer to the valve catalogs for detailed specifications of the valves to mount actuators.
- Cylinder bodies of double action type and spring return type are interchangeable. Double action type can be converted to spring return type by changing spring cartridge.
- Actuator sizing may differ for the particular service conditions when converting double action type to spring return type. Contact KITZ Corporation for proper sizing.
- Standard operating pressure built-in spring return type is 4K. (0.39 to 0.69MPa)
- Spring cartridge with different operating pressures 3K (0.29 to 0.69MPa) and 5K (0.49 to 0.69MPa) is optionally available. Contact KITZ Corporation for actuator sizing of 3K and 5K types.
- Do not use excessive operating pressures to actuators, which will damage internal parts and result in malfunction.
- Ensure to use compressed instrumentation air or nitrogen gas as operating medium.
- It will damage internal and external parts to use actuators under corrosive environments.
 1. Holding valve position
KITZ pneumatic actuators do not assure no leakage. Actuators do not hold valve positions long time without continuous air supply. If you need to hold valve position long time without continuous air supply, contact KITZ Corporation or its distributors.
 2. Internal air residue of spring return type actuators
Out put torques of spring return type actuators indicate valves without internal air residue remains inside their cylinders. Please design your systems to be able to exhaust internal air residue at spring return action. If internal air residue remains in the cylinders, the out put torque will be small and valves do not open or close by spring return action.
- Air supply inlet threads are Rc $\frac{1}{4}$ as standard. Ensure to use piping tubes which diameters are $\phi 6$ and smaller. Contact KITZ Corporation to reduce operating time with larger diameter piping tube.
- It is recommended to use KITZ standard accessories for F Series actuators.
- Ensure to select solenoid valves suitable for the service conditions.
- Specify piping positions when using actuated valves with positioners since piping positions may make opening slip.
- A part to avoid entering water into a spring case ("Mizukiller") is installed on spring return type actuator's breathing port. And The Mizukiller is sealed with a sticker. Remove the sticker before running automated operation.
(For products shipped before December 2009, a cap is installed on spring return type actuator's breathing port instead of the Mizukiller. Remove the cap before running automated operation. If the cap remains, actuator speed may become slow.)
- When Type FAS spring return actuator is used outside or in wet condition, the Mizukiller has to be installed into it. If the Mizukiller is not installed, water may enter into a spring unit and cause a malfunction.
- KITZ is not responsible for any products modified by the purchasers.

WARNING

- Spring cartridge for spring return type has strongly compressed built-in spring. Careful handling of spring cartridge is required to avoid its blowing out. Do not loosen stopper bolt of spring cartridge.
- Do not remove end covers and spring covers or disassemble actuators while they are pressurized.

CAUTION

Technical data published in this catalog have been developed from our design calculation, in-house testing, field reports provided by our customers and/or published official standards or specifications. They are good only to cover typical applications as a general guideline to users of KITZ products introduced in this catalog.

For any specific application, users are kindly requested to contact KITZ Corporation for technical advice, or to carry out their own study and evaluation for proving suitability of these products to such an application. Failure to follow this request could result in property damage and/or personal injury, for which we shall not be liable.

While this catalog has been compiled with the utmost care, we assume no responsibility for errors, impropriety or inadequacy. Any information provided in this catalog is subject to from-time-to-time change without notice for error rectification, product discontinuation, design modification, new product introduction or any other cause that KITZ Corporation considers necessary. This edition cancels all previous issues.

Memo

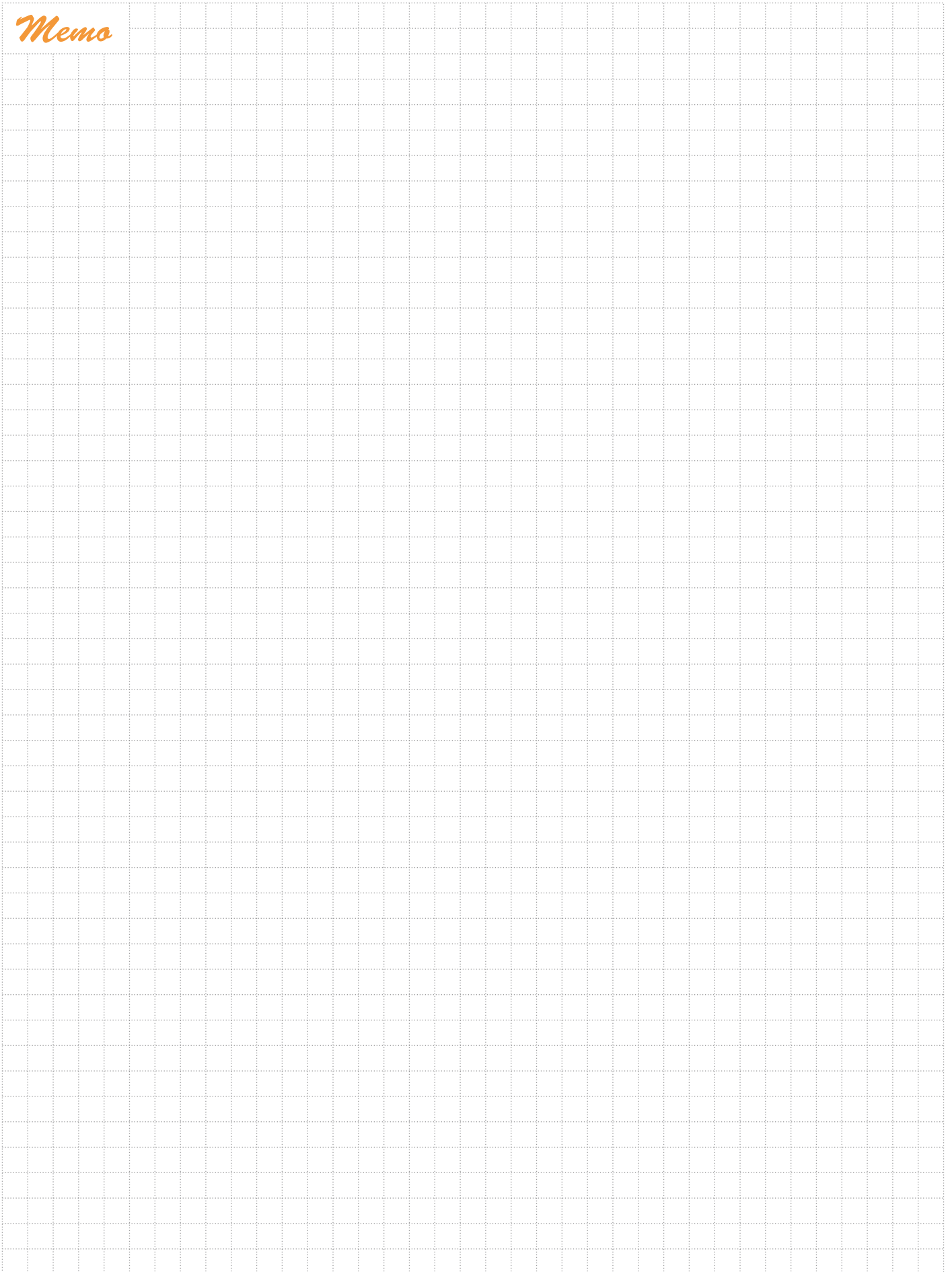

CAUTION

Pressure-temperature ratings and other performance data published in this catalog have been developed from our design calculation, in-house testing, field reports provided by our customers and/or published official standards or specifications. They are good only to cover typical applications as a general guideline to users of KITZ products introduced in this catalog.

For any specific application, users are kindly requested to contact KITZ Corporation for technical advice, or to carry out their own study and evaluation for proving suitability of these products to such an application. Failure to follow this request could result in property damage and/or personal injury, for which we shall not be liable.

While this catalog has been compiled with the utmost care, we assume no responsibility for errors, impropriety or inadequacy. Any information provided in this catalog is subject to from-time-to-time change without notice for error rectification, product discontinuation, design modification, new product introduction or any other cause that KITZ Corporation considers necessary. This edition cancels all previous issues.

Read instruction manual carefully before use.

NOTICE

If any products designated as strategic material in the Foreign Exchange and Foreign Trade Law, Cabinet Order Concerning Control of Export Trade, Cabinet Order Concerning Control of Foreign Exchange and other related laws and ordinances ("Foreign Exchange Laws") are exported to any foreign country or countries, an export license issued by the Japanese Government will be required under the Foreign Exchange Laws.

Further, there may be cases where an export license issued by the government of the United States or other country will be required under the applicable export-related laws and ordinances in such relevant countries.

The contract shall become effective subject to that a relevant export license is obtained from the Japanese Government.

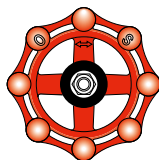

*A chrysanthemum-handle is a symbol of KITZ,
the brand of valve reliability*

ISO 9001 certified since 1989

KITZ
KITZ CORPORATION

1-10-1, Nakase, Mihama-ku, Chiba 261-8577, Japan
International Sales Dept. Phone : 81-43-299-1730, 1732 and 1733
Fax : 81-43-299-0121

— Distributed by —