

HERCULES

Spindle runout
0.0002" maximum-
Guaranteed



3HP/5HP
Variable optional
milling head



High precision
Taiwan SHYHMIN
lead screw



Italy high precision
P4 BRZ spindle
bearings (Made in
Italy)



Multi-function quill
feed speed



Hand scratching
sideway, perfect
combination

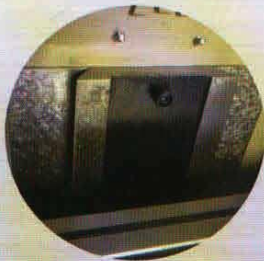

Durable one shot
lubrication system



Hardened slideway with
annealing and stress
relieving with Turcite B
coating

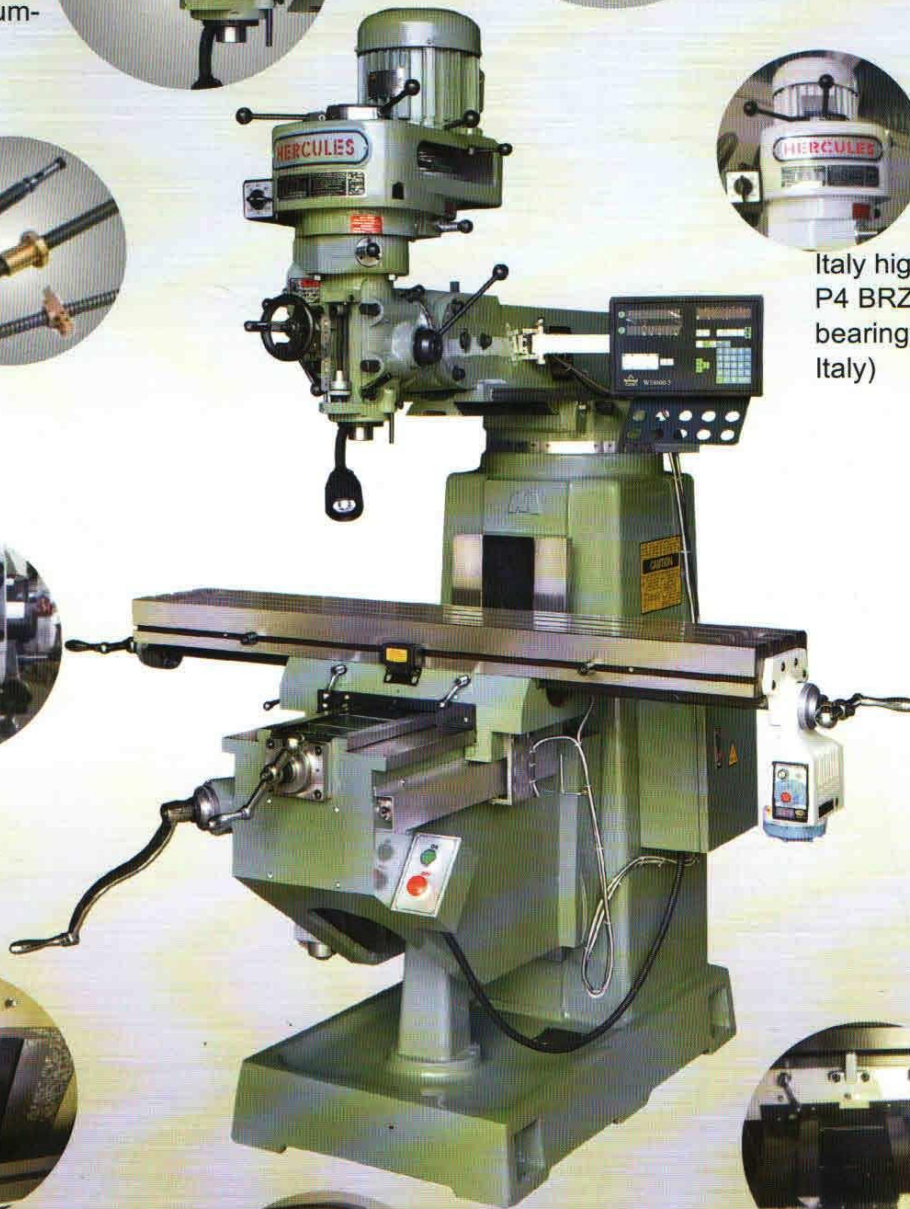

TECHNICAL SPECIFICATION :-

VERTICAL TURRET MILLING MACHINE

| SPECIFICATION | M3 | M4 |
|--------------------------|---|---------------------------|
| Table Size | 1270mmx254mm 50" x 10" | 1370mmx254mm 54" x 10" |
| Table Travel (X x Y x Z) | 850x400x405 | 950x400x405 |
| Ram Travel | 380mm | |
| T-Slot (Number with) | 3x16mm | |
| Spindle Speed | Standard: 16 steps 80-4620rpm Optional : Variable 70-3600rpm | |
| Quill Feed Speed | 0.04, 0.08, 0.15 mm/rev | |
| Spindle Travel | 127mm | |
| Spindle Hole taper | Standard : R8/NT 30 (Optional) : Nt40 | |
| Spindle nose to table | 40-440mm | 45-465mm |
| Main Motor power | 3HP | |
| Net Weight | 1100Kgs. | 1200Kgs. |

ACCESSORIES :



2 Axis DRO



Collet Set



Clamping Kit 52 Pcs.



Machine Vice

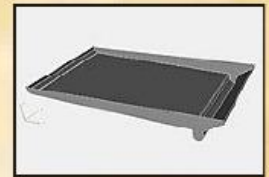

Chip Pan Tray



X & Y Axis Power Feed



Keyless Drill Chuck



Boring Head Set



Right Angle Attachment



Rotary Table



Coolant Pump



Air Power Draw Bar
(Optional)



LED Work Light
(Optional)



Spindle Guard
(Optional)



Automatic Lubricator
(Optional)

GARIMA
MARKETING

H.O.: 5C-77, N.I.T., Faridabad - 121001

Tel.: 0129-4029859

M : +91-9312499859, +91-9311507241

E-mail : garima9844@gmail.com

info@garimamarketing.in

Website : www.garimamarketing.in

Office Cum Godown : 3A-170, Near Chimani Bhai Dharamshala, N.I.T. Faridabad - 121001